

TM 1-1520-238-PM

TECHNICAL MANUAL

**PHASED MAINTENANCE INSPECTION CHECKLIST
FOR**

**ARMY
AH-64A HELICOPTER**

“Approved for public release; distribution is unlimited”

TM 1-1520-238-PM dated TBD supersedes TM 1-1520-238-PM dated 30 June 1994, including all changes.

**HEADQUARTERS, DEPARTMENT OF THE ARMY
28 FEBRUARY 2002**

INSERT LATEST CHANGED PAGES: DESTROY SUPERCEDED PAGES.

LIST OF EFFECTIVE PAGES

NOTE: The portion of the text affected by the changes is indicated by a vertical line in the outer margins of the page. Changes to illustrations are indicated by miniature pointing hands. Changes to wiring diagrams are indicated by shaded areas.

Date of issue for original and change pages are:

Original 0 28 February 2002

TOTAL NUMBER OF PAGES IN THIS PUBLICATION IS 144, CONSISTING OF THE FOLLOWING:

Page No.	*Change No.	Page No.	*Change No.
Cover	0	2-33 – 2-37	0
Blank	0	2-38 Blank	0
Title	0	2-39 – 2-43	0
Blank	0	2-44 Blank	0
A	0	2-45 – 2-75	0
B Blank	0	2-76 Blank	0
1-1 – 1-18	0	2-77 – 2-87	0
2-1 – 2-5	0	2-88 Blank	0
2-6 Blank	0	2-89 – 2-97	0
2-7 – 2-19	0	2-98 Blank	0
2-20 Blank	0	2-99 – 2-103	0
2-21 – 2-25	0	2-104 Blank	0
2-26 Blank	0	2-105 – 2-119	0
2-27 – 2-31	0	2-120 Blank	0
2-32 Blank	0		

*Zero in this column indicates an original page.

***TM 1-1520-238-PM**

**HEADQUARTERS
DEPARTMENT OF THE ARMY
WASHINGTON, D.C., 28 February 2002**

AH-64A HELICOPTER

PHASED MAINTENANCE CHECKLIST

WARNING

CERTAIN INSPECTIONS ARE MANDATORY SAFETY-OF-FLIGHT REQUIREMENTS, AND THE INSPECTION INTERVALS CANNOT BE EXCEEDED. IN THE EVENT THESE INSPECTIONS CANNOT BE ACCOMPLISHED AT THE SPECIFIED INTERVAL, THE AIRCRAFT CONDITION STATUS SYMBOL WILL BE IMMEDIATELY CHANGED TO A RED X. MANDATORY SAFETY-OF-FLIGHT INSPECTION ITEMS ARE PRINTED IN BOLD FACE TYPE.

NOTE

INSPECTION ITEMS CONTAINED IN THIS MANUAL ARE CONSIDERED THE MINIMUM REQUIREMENTS FOR PERFORMING PHASED MAINTENANCE AND MUST BE PERFORMED. THE CUMULATIVE EFFECTS OF INSPECTION DEFERRALS ARE UNKNOWN AND COULD RESULT IN CATASTROPHIC FAILURE OR INCREASED MAINTENANCE AT A LATER DATE. THEREFORE, THE USE OF SPECIAL LETTERING TO EMPHASIZE MANDATORY SAFETY-OF-FLIGHT INSPECTION ITEMS IS NOT TO BE CONSTRUED AS AUTHORITY FOR DEFERRAL OF OTHER INSPECTIONS.

*TM 1-1520-238-PM dated TBD supersedes TM 1-1520-238-PM dated 30 June 1994, including all changes.

SECTION I. GENERAL INFORMATION

PHASED SCHEDULE. Phased maintenance inspection contains requirements for inspection of the AH-64A helicopter on a phased schedule having a 1000-hour cycle with 250-hour phases. Each requirement included herein is designated for accomplishment at least once, but not more than four times during the 1000-hour cycle.

EXCEEDING THE PHASED SCHEDULE. The phased maintenance inspection intervals designated are the maximum and shall not be exceeded except in actual operational emergencies as explained herein. It is the Commander's responsibility to determine (on an individual aircraft basis) when inspection intervals may be exceeded. For this purpose, operational emergencies are conditions of combat, or conditions of disaster which necessitate flight to evacuate aircraft or personnel. Those inspections annotated by a "C" in the Inspect Phase Nos. column, along with the DA Form 2408-18 (Equipment Inspection List), are considered the MINIMUM mandatory combat maintenance inspection requirements for helicopters scheduled for imminent deployment to or stationed in a combat environment. Under no circumstances will two combat maintenance inspections be performed sequentially. When aircraft are operated beyond the normal inspection due time because of such emergency situations, a circled red X status symbol and an appropriate statement (to include authority) must be entered in block 16 and 17 of DA Form 2408-13 (Aircraft Inspection and Maintenance Record) until such time as the inspection is complete. When inspections are delayed to meet emergency requirements, Commanders will assure that the aircraft status symbol reverts to a red X and that delayed inspections are accomplished immediately upon termination of the emergency. When unusual local conditions (utilization, type of mission, personnel, periods of inactivity, environmental conditions, etc.) dictate, it is the prerogative and responsibility of the Maintenance Officer to increase the scope and/or frequency of maintenance or inspection as necessary to ensure safe operation (TM 1-1500-328-23).

MAINTENANCE ACTIVITIES. The inspections prescribed by this checklist will be accomplished at specified phases by Aviation Unit Maintenance (AVUM) activities with assistance of Aviation Intermediate Maintenance (AVIM) and Depot Maintenance activities when required. The inspection of the part/component is visual unless stated otherwise.

LIMITATIONS. The checklist does not contain instructions for repair, adjustment, or other means of rectifying conditions. Neither does it contain special tolerances, limits, or instructions for special troubleshooting to find causes for malfunctions. Such data will be obtained from the latest issue of the aircraft TM 1-1520-238-23 –series Maintenance Manuals.

CHANGEOVER TO THE PHASED MAINTENANCE SYSTEM. Changeover shall be accomplished in accordance with instructions provided in TB 55-1500-337-24 entitled, "Phased Maintenance System for Army Aircraft." The requirements of this TB must be accomplished prior to implementation of Phase 1 inspection requirements specified in this checklist.

PRE-INSPECTION MAINTENANCE TEST FLIGHT (MTF). A pre-inspection MTF to duplicate non-hazardous equipment problems, determine unsatisfactory conditions, determine equipment operation problems, etc., is recommended prior to start of aircraft disassembly for phased maintenance inspection. The decision to perform the pre-inspection MTF, however, shall be the responsibility of the unit Maintenance Officer.

SPECIAL INSPECTIONS, CALENDAR INSPECTIONS, AND LUBRICATION REQUIREMENTS. Special inspections, calendar inspections, and lubrication requirements contained in TM 1-1520-238-23 and those listed on the aircraft's DA Form 2408-18 shall be reviewed and accomplished in accordance with the "inspection due" requirements specified in those documents.

TM 1-1520-238-PM

TIME BETWEEN OVERHAUL (TBO) AND RETIREMENT LIFE ITEMS CHECK. Prior to start of the applicable phased maintenance inspections and lubrication, a check will be made of components and their remaining operating hours prior to removal. The latest issue of the aircraft's TM 1-1520-238-23 and DA Form 2408-16 shall be referred to for a complete listing of components and their TBO and retirement life.

USING THE PHASED INSPECTION CHECKLIST.

a. A new checklist shall be used each time phased maintenance is due on the aircraft. This checklist is arranged such that it can be separated by area and distributed to the maintenance crew.

(1) Space is provided on each checklist form for entering the following data:

- (a) The number of the maintenance inspection being performed.
- (b) Aircraft serial number.
- (c) Date of inspection.
- (d) Total hours. (Block provided for local use.)

(2) For each inspection item a column is provided for entering the following data:

- (a) Status of the aircraft as the result of the inspection requirement.
- (b) Aircraft fault and/or remarks indicated by the inspection requirement.
- (c) Action taken to correct the fault.
- (d) Initials of person performing the corrective action.

b. This checklist is formatted to eliminate the requirements to use DA Form 2404 as temporary records during phased inspections. Figures 1 thru 3 show examples of methods used to make entries on the phased maintenance checklist forms and the use of supplemental sheets for continuation purposes. This checklist pertains to all AH-64A helicopters and may, therefore, contain inspection requirements applicable to specific equipment not installed on individual aircraft. When this situation is encountered, those requirements that are not applicable need not be performed.

c. A supplemental Checklist Sheet form (DA Form 4676-R) (figure 3, Sheet 2) provided at the end of Section I of this checklist is to be used for local reproduction. Copies of this form will be used to write up faults, remarks, and corrective actions when additional space is required. These supplemental sheets will be used instead of DA Form 2404 in the accomplishment of the phased maintenance inspections.

d. Faults and remarks on the DA Form 2408-13 and DA Form 2408-14 may be transcribed to this checklist at the discretion of the unit Maintenance Officer.

PHASE NUMBERS. In the column headed "Inspect Phase Nos." and adjacent to the sequence number of each inspection requirement, there will appear the word "ALL" or a series of numbers. The word "ALL" indicates that inspection requirements shall be accomplished at each phase (or at every 250-hour interval of the 1000-hour cycle). The numbers represent the phase number at which that inspection requirement is to be accomplished. For example, if the numbers 2 and 4 are shown, that inspection requirement is to be accomplished at phases 2 and 4 only (or at 500-hour interval). If only one number is indicated, then that inspection requirement is accomplished at that phase (or at every 1000-hour interval). At the completion of phase 4, the cycle starts over again with Phase 1.

TM 1-1520-238-PM

STATUS SYMBOLS. All faults and deficiencies discovered during the inspection will be recorded on DA Form 2408-13-1/2408-13-1-E. The status symbols used are the same as those defined in DA PAM 738-751. The status symbol shall be entered by the person(s) performing the inspection and is determined by the type of fault that is found. Do not enter a horizontal dash (–) on the checksheet merely to show a particular inspection requirement is due. If an inspection reveals no fault, a status symbol will not be entered. The person clearing the fault shall place his last name initial over the status symbol. A red X or a circled red X symbol will not be initialed over until after the corrective action has been approved and signed off by a Technical Inspector or designated supervisor.

FAULTS AND/OR REMARKS. Fault entries in the Faults and/or Remarks column shall be brief remarks which describe the conditions resulting from the inspection and which require corrective action. The initials of the person making the entry will be entered immediately after the entry. If no fault is found, this column will be left blank.

ACTION TAKEN.

a. Entries in the Action Taken column shall be brief remarks which describe the action taken to correct the fault described in the adjacent Faults and/or Remarks column. When faults are assigned a red X status, the corrective action shall be inspected and signed off by the Technical Inspector or designated supervisor.

b. If no fault was found, an appropriate remark shall be entered in this column to indicate that the inspection was accomplished, e. g., “Inspected and found OK.” If an inspection item is not applicable to the particular inspection phase number in work or to specific equipment installed on an individual aircraft, a “N/A” entry is required. The initials of the person making the entry shall be entered in the Initial column.

INITIAL. The person correcting the indicated fault shall enter his initials in the initial column opposite the first line of the Action Taken entry.

FINAL RECORDS CHECK. After all corrective actions have been completed and following completion of the phased inspection, the Technical Inspector or designated supervisor shall verify that all applicable forms and records have been properly updated. All uncorrected faults shall be entered on DA Form 2408-13, prepared for that date or to the DA Form 2408-14. A Final Records Checklist (table I) is provided to ensure forms and records have been inspected for completeness and accuracy prior to release of the aircraft from the phased maintenance inspection. The inspector verifying the final records check shall enter his initials adjacent to the indicated form on the Final Records Checklist. The initials entered shall be registered on the Signature Sheet (table II) adjacent to that person’s signature.

SIGNATURE SHEET. All personnel performing inspection and/or maintenance tasks shall place their signatures and initials on the signature sheet (table II). The purpose of the signature sheet is to provide a correlation between initials entered on the individual checklist sheets and the actual names of the personnel accomplishing these tasks.

MAINTENANCE OPERATIONAL CHECKS. After the completion of any required corrective actions to any of the components of a functional system of the aircraft, maintenance operational checks (MOC) shall be performed on that system to determine the effectiveness of the maintenance actions performed and to verify the proper operation of that system. These MOC shall be performed in accordance with TM 1-1500-328-23. Copies of supplemental sheets (DA Form 4676-R) may be used to record and sign off the Maintenance Operational Checks performed.

MAINTENANCE TEST FLIGHT. When all required inspections in Section II have been accomplished and initialed in accordance with the above procedure, a daily inspection in accordance with the TM specified in Section II will be performed on the aircraft to permit performance of a maintenance test flight (MTF). The MTF shall be performed in accordance with the requirements of TM 1-1520-238-23 and TM 1-1500-328-23 using the MTF form in the MTF technical manual. A suggested maintenance test flight checksheet (figure 4) and a rotor smoothing record (figure 5) are provided at the end of Section I.

TM 1-1520-238-PM

CHECKLIST DISPOSITION. The completion of each phased maintenance inspection shall be recorded on DA Form 2408-13 and 2408-15 as prescribed by DA PAM 738-751. The signed checklist, together with all continuation sheets, shall be attached to DA Form 2408-13 and filed for the six months period as required by DA PAM 738-751. At the end of the six months period, records will be destroyed per disposition instruction for DA Form 2408-13-1/2408-13-1-E in paragraph 2-9.D.(2) of DA Pamphlet 738-751.

INSPECTION AREAS. Figure 6 reflects the inspection areas of the AH-64A helicopter. Those areas are titled as shown. Figure 7 shows the location of access doors and panels which require removal at various phased maintenance inspections.

REPORTING ERRORS AND RECOMMENDING IMPROVEMENTS. You can help improve this manual. If you find any mistakes or if you know of a way to improve the procedures, please let us know. Mail your letter, DA Form 2028 (Recommended Changes to Publications and Blank Forms), or DA Form 2028-2 located in the back of this manual direct to: Commander, U.S. Army Aviation and Missile Command, ATTN: AMSAM-MMC-MA-NP, Redstone Arsenal, AL, 35898-5230. A reply will be furnished to you.

PHASE NO. <u>1</u>		PHASED MAINTENANCE CHECKLIST			
Area Name and No. LEFT FORWARD AVIONICS BAY AND MLG		Aircraft Serial No. 77-23259		Date 4 APR 81	Total Hrs. This Area 510
Inspect Phase Nos.	Inspection Requirements	Status	Faults and/or Remarks	Action Taken	Initial
ALL C	1. MLG wheel for cracks, distortion, or corrosion. Hub for grease leakage. Tire for INDICATES COMBAT SITUATION INSPECTION			<i>Insp - OK</i>	<i>WCB</i>
ALL C	2. MLG wheel brake for fluid leakage, cracked housing or corrosion. Check brake pucks for wear.	<i>B</i>	<i>corrosion on bottom of brake housing WCB</i>	<i>Cleaned off</i>	<i>WCB</i>
		<i>B</i>	<i>Leakage from housing inlet connection WCB (continued on Supplemental Sheet)</i>	<i>Inlet fitting tightened</i>	<i>WCB</i>
2,4	3. Search light for corrosion, loose or missing fasteners, and security. Lens for cracks or evidence of overheating. Wiring for loose connections. Chafing, deterioration, and security.		THIS ITEM NOT APPLICABLE TO PHASE NO. 1	<i>N/A</i>	<i>WCB</i>
<p>EXAMPLE</p> <p>HEAVY LINES ADDED TO SEPARATE FAULTS WITHIN A BLOCK</p> <p>Entries shown above are fictitious and are intended only to illustrate usage of form.</p>					

Figure 1. Example of Phased Maintenance Checklist Title Sheet

PHASE NO. <u>2</u>		Area Name and No. MAIN TRANSMISSION - 9		Aircraft Serial No. 77-23259		Date 4 APR 81	
Inspect Phase Nos.	Inspection Requirements	Status	Faults and/or Remarks	Action Taken	Initial		
2,4	5. Breathers cleaned. Access L200, R200			<i>Insp - OK</i>	<i>WCB</i>		
ALL	6. Lube oil and filters changed. Access L200, R200			<i>Insp - OK</i>	<i>WCB</i> <i>GDL</i>		
ALL	7. Lube oil level sight gages for cleanliness, leakage, and security. Clean lenses. Access L200, R200	<i>B</i>	<i>Sight gage Loose WCB</i>	<i>Tightened</i>	<i>WCB</i>		
2,4	8. Input shafts and couplings for cracks, dents, distortion, and corrosion. Access L200, R200, LN6, RN6	<i>X</i>	<i>No. 2 shaft input Coupling diaphragm cracked WCB</i>	<i>Coupling replaced</i>	<i>WCB</i>		
					QA INITIALS ON LAST LINE.		
					QA SIGN OFF.		
				<i>Insp - OK Harold S. Smith</i>	<i>HSS</i>		
	<i>Uncorrected Fault/ Discrepancy from DA form 2408-13</i>	<i>X</i>	<i>(6 Mar 81) Defective Chip</i>	<i>Rewired</i>	<i>RCJ</i> <i>RMP</i>		
	INSPECTION ITEM ADDED TO AVAILABLE SPACE ON A CHECKLIST PAGE.				A DIFFERENT PERSON CORRECTED THIS FAULT.		

Entries shown above are fictitious and are intended only to illustrate usage of form.

Figure 2. Example of Phased Maintenance Checklist Continuation Sheet

PHASED MAINTENANCE CHECKLIST (SUPPLEMENTAL SHEET)					DATE	
For use of this form, see TM 55-1510 series and TM 55-1520 series, the proponent agency is the US Army Materiel Development and Readiness Command.					4 APR 81	
PHASE NO.	AREA NAME AND NUMBER			AIRCRAFT SERIAL NO.	TOTAL HOURS THIS AREA	
1	LEFT FWD AVIONICS BAY AND MLG -3			77-23259		
INSPECT AREA NO.	INSPECT ITEM NO	INSPECTION REQUIREMENTS	STATUS	FAULTS AND/OR REMARKS	ACTION TAKEN	INITIAL
3	9	(continued)	B	Brake puck worn, unserviceable WCB	Replaced	WCB
<p>A SUPPLEMENTAL SHEET IS USED WHEN SPACE IS NOT AVAILABLE ON CHECKLIST PAGE FOR ALL FAULTS OR CORRECTIVE ACTION.</p>						
<p>"FOD REMINDER"</p> <p style="font-size: small;">Check work area for tools and parts after completion of maintenance and Inspection.</p>						

EXAMPLE

Figure 3. Example of Checklist Supplemental Sheet (Sheet 1 of 2)

3. ENGINE OVERSPEED TEST		4. AUTOROTATION	
a. ENG 1		a. PRESS ALT FT	
b. ENG 2		b. FAT °C	
4. ECU LOCK OUT		c. N _R %	
a. ENG 1		d. FUEL LBS	
b. ENG 2		5. ATTITUDE HOLD	
5. SDC/PAS		6. MANEUVERING FLIGHT	
6. FUEL SYSTEM		7. STABILATOR SYSTEM	
BEFORE TAXI CHECK		8. V _H FLIGHT	
1. DEK - FD / LS		ENGINE PERFORMANCE	
a. XMSN 1 PSI °C		1. MAXIMUM POWER CHECK	
b. XMSN 2 PSI °C		a. PRESS ALT FT	
c. NGB 1 PSI °C		b. FAT °C	
d. NGB 2 PSI °C		ENG 1 2	
2. ENG 1 2		c. TGT °C °C	
a. N _G % %		d. TORQUE % %	
b. N _P % %		e. N _G %	
c. N _R % %		2. TGT LIM/CONTGCY PWR CK	
d. TGT °C °C		a. TORQUE % %	
e. OIL PRESS PSI PSI		b. TGT °C °C	
f. TORQUE % %		MISSION EQUIPT CHECKS	
3. HIT CHECK		1. NAV COM EQUIPT CKS	
TAXI CHECK		2. PNVS SYSTEM CHECK	
1. WHEEL BRAKES		3. TADS SYSTEM CHECK	
2. INSTRUMENT & SYMBOLOGY		4. WEAPON SYSTEMS CHECKS	
HOVER CHECKS		BEFORE LANDING	
1. INITIAL HOVER CHECK		AFTER LANDING	
2. INSTRUMENT CHECKS		ENGINE SHUTDOWN	
3. HOVER MANEUVERING CHECK		1. PILOT	
4. DASE/HARS CHECK		2. CPG	
5. VISIONIC SYSTEM CHECK		BBC	
6. DOPPLER DRIFT		3. APU FIRE PULL	
FLIGHT CHECKS		4. EMERGENCY HYDRAULICS	
1. TAKE OFF		5. UTILACC PRESSURE PSI	
2. CRUISE		BEFORE LEAVING HELICOPTER	
3. FUEL COMSUMPTION CHECK			
START STOP			
LBS PER HOUR			

Figure 4. Example of Maintenance Test Flight Checksheet (Sheet 2 of 3)

REMARKS		SIGNATURE
----------------	--	------------------

S840275-7

Figure 4. Example of Maintenance Test Flight Checksheet (Sheet 3 of 3)

BLADE NO. 1 SERIAL NUMBER					BLADE NO. 2 SERIAL NUMBER				
ADJUSTMENT NUMBER	TAB	PITCH LINK ADJ	BALANCE	EFFECT	ADJUSTMENT NUMBER	TAB	PITCH LINK ADJ	BALANCE	EFFECT
1.					1.				
2.					2.				
3.					3.				
4.					4.				
5.					5.				
REMARKS									
PILOT SIGNATURE _____									

EXAMPLE

Figure 5. Example of Rotor Smoothing Record

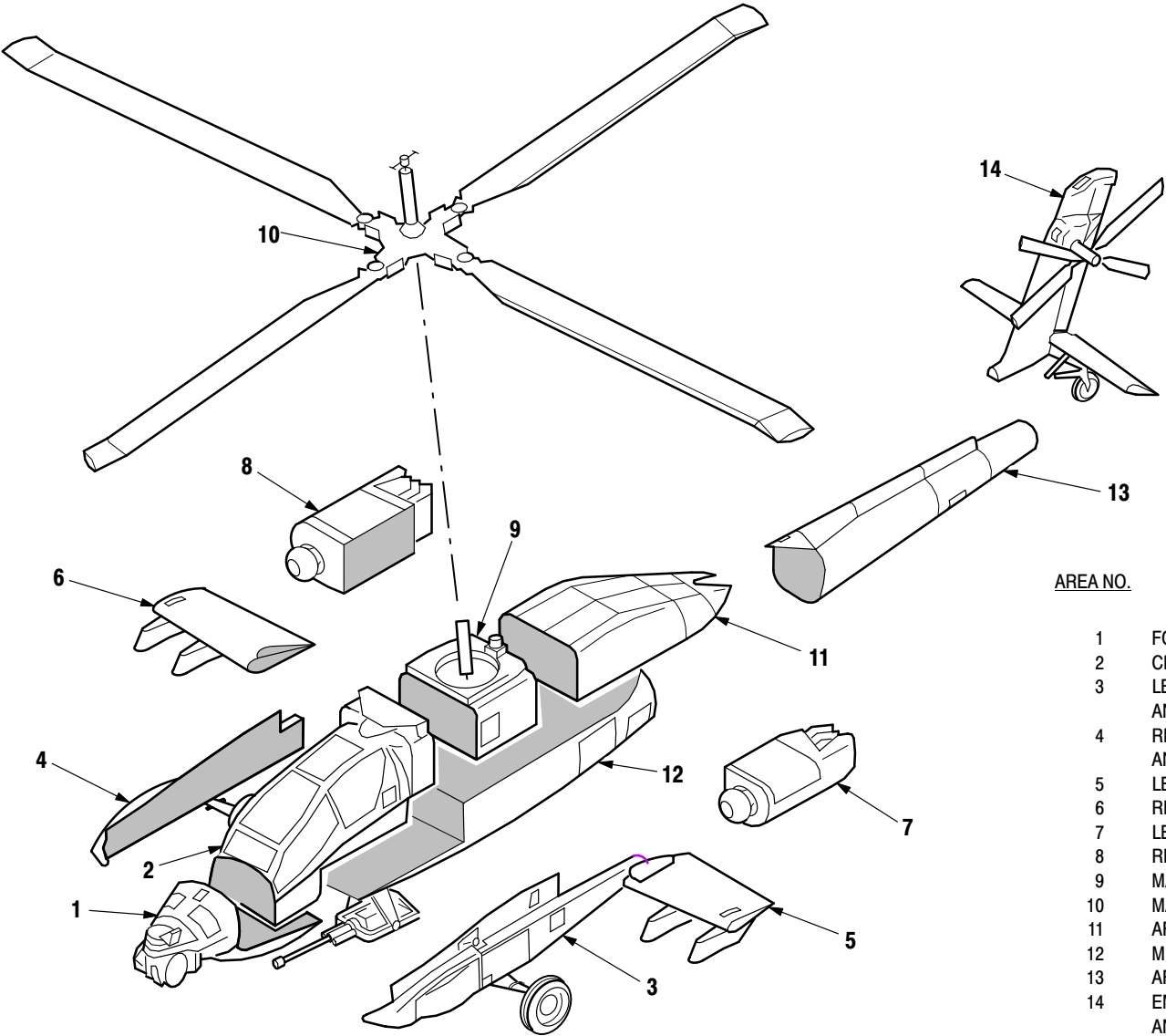

AREA NO.	AREA TITLE
1	FORWARD FUSELAGE
2	CREW STATIONS
3	LEFT FORWARD AVIONICS BAY AND MAIN LANDING GEAR
4	RIGHT FORWARD AVIONICS BAY AND MAIN LANDING GEAR
5	LEFT WING AND PYLONS
6	RIGHT WING AND PYLONS
7	LEFT ENGINE AND NOSE GEARBOX
8	RIGHT ENGINE AND NOSE GEARBOX
9	MAIN TRANSMISSION
10	MAIN ROTOR
11	AFT EQUIPMENT BAY
12	MID AND LOWER FUSELAGE
13	AFT FUSELAGE
14	EMPENNAGE, TAIL ROTOR, AND TAIL LANDING GEAR

M06-002

Figure 6. Inspection Area Diagram

TM 1-1520-238-PM

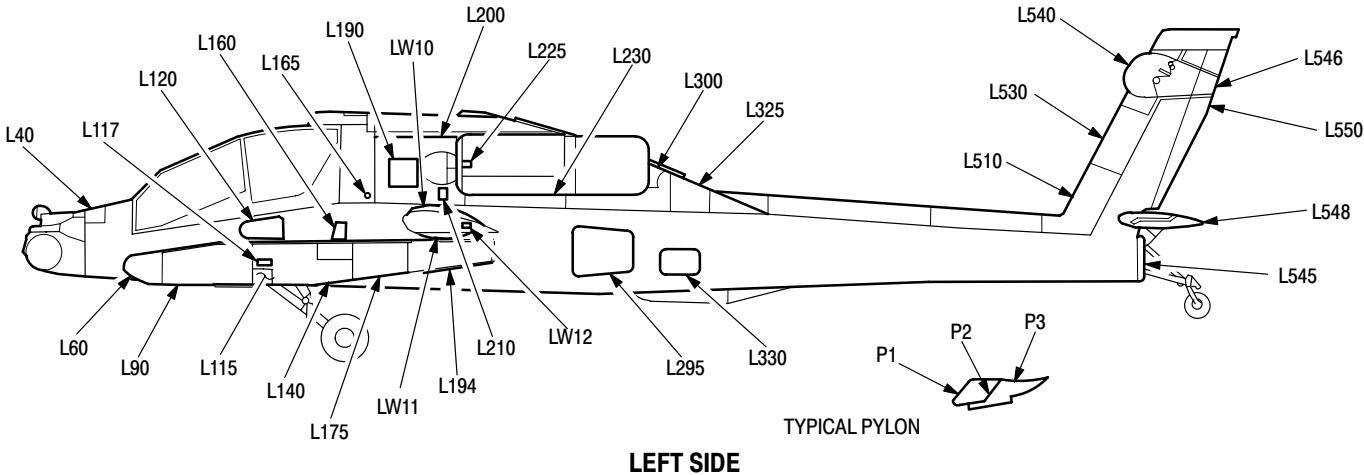

LEFT SIDE

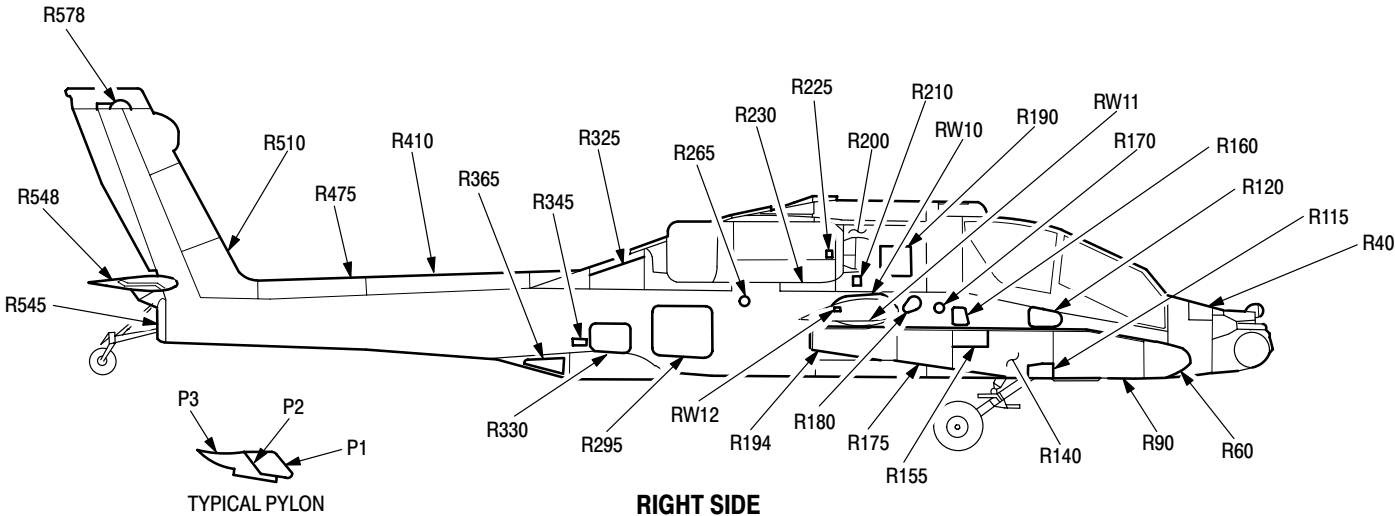

RIGHT SIDE

M06-003-1

Figure 7. Inspection Access Provisions (Sheet 1 of 2)

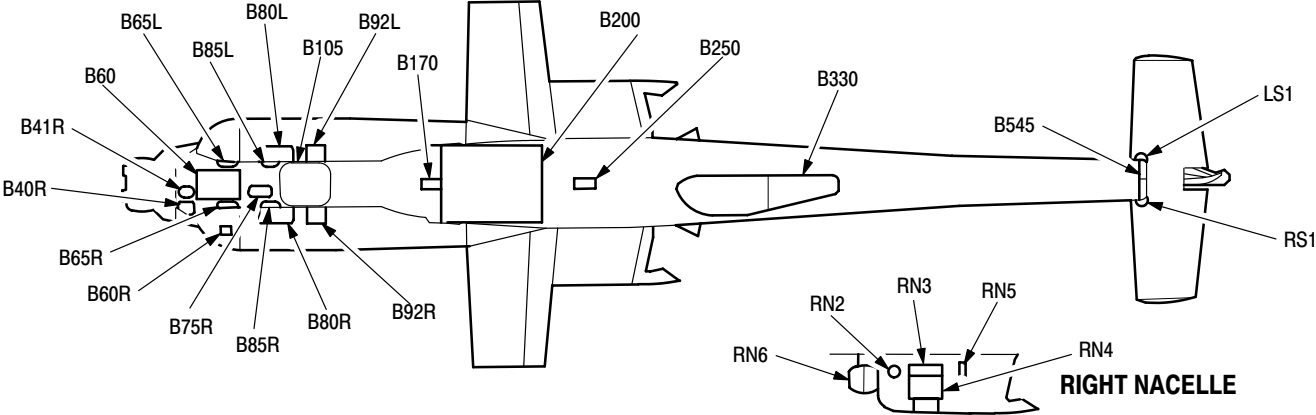
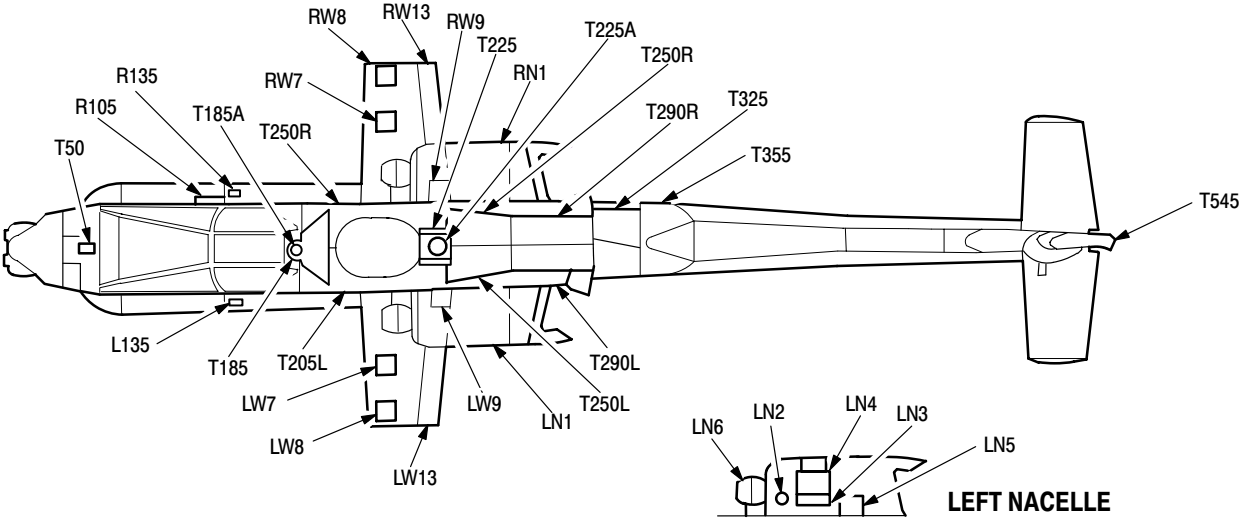

M06-003-2

Figure 7. Inspection Access Provisions (Sheet 2 of 2)

TM 1-1520-238-PM

Table I. Final Records Checklist

This checklist is provided to ensure that the indicated forms and records have been inspected for presence, completeness, legibility and accuracy prior to releasing the aircraft from a phased inspection. Verification of inspection will be indicated by placing the initials of the inspector in the appropriate initial block.

AIRCRAFT LOG BOOK	INITIAL	HISTORICAL RECORDS	INITIAL
DA FORM 2408		DA FORM 2408-5	
DA FORM 2408-12			
DA FORM 2408-13			
DA FORM 2408-14		DA FORM 2408-9	
DA FORM 2408-18		DA FORM 2408-15	
TM 1-1520-238-PMS		DA FORM 2408-16	
		DA FORM 2408-17	
TM 1-1520-238-MTF		DA FORM 2408-19	
LOCALLY REQUIRED FORMS		LOCALLY REQUIRED FORMS	

PRODUCTION CONTROL RECORDS	INITIAL	QUALITY CONTROL	INITIAL
FLOW CHART		TBO FILE	
STATUS BOARD		QA FILE	
WORK ORDER FILE		SERIAL NUMBER FILE	
MWO FILE		AOAP FILE	
CONFIGURATION CHART		INVENTORY RECORDS	
2405 LOG		WEIGHT AND BALANCE	
1352 REPORTS		MSG FILE	
LOCAL RECORDS		DA FORM 2410 SUBMITTED	
		LOCAL RECORDS	

TM 1-1520-238-PM

Table II. Signature Sheet

_____ Signature of Person Accomplishing Necessary Work	_____ Initial
_____ Signature of Person Accomplishing Necessary Work	_____ Initial
_____ Signature of Person Accomplishing Necessary Work	_____ Initial
_____ Signature of Person Accomplishing Necessary Work	_____ Initial
_____ Signature of Person Accomplishing Necessary Work	_____ Initial
_____ Signature of Person Accomplishing Necessary Work	_____ Initial
_____ 	_____ Initial
_____ 	_____ Initial
_____ Signature of Maintenance Supervisor	_____ Initial
_____ Signature of Technical Inspector	_____ Initial
_____ Signature of Maintenance Officer	_____ Initial

TM 1-1520-238-PM

Table III. Signature Sheet

_____ Signature of Person Accomplishing Necessary Work	_____ Initial
_____ Signature of Person Accomplishing Necessary Work	_____ Initial
_____ Signature of Person Accomplishing Necessary Work	_____ Initial
_____ Signature of Person Accomplishing Necessary Work	_____ Initial
_____ Signature of Person Accomplishing Necessary Work	_____ Initial
_____ Signature of Person Accomplishing Necessary Work	_____ Initial
_____ 	_____ Initial
_____ 	_____ Initial
_____ Signature of Maintenance Supervisor	_____ Initial
_____ Signature of Technical Inspector	_____ Initial
_____ Signature of Maintenance Officer	_____ Initial

SECTION II. INSPECTION CHECKLIST

WARNING

ACCIDENTAL ACTUATION OF HELICOPTER POWER PLANT, HYDRAULIC SYSTEM, CANOPY JETTISON SYSTEM, OR FIRING OF ARMAMENT OR STORES JETTISON BALLISTICS MAY CAUSE SEVERE INJURY OR DEATH. BEFORE STARTING INSPECTION, HELICOPTER SAFETY CHECK MUST BE PERFORMED (TM 1-1520-238-23) AND ALL ARMAMENT MUST BE SAFETIED, DEACTIVATED, AND CLEARED (TM 9-1090-208-23 AND TM 9-1427-475-23).

NOTE

PRIOR TO START OF THE PHASED MAINTENANCE INSPECTION, IT IS RECOMMENDED THAT A PRE-INSPECTION MAINTENANCE TEST FLIGHT (MTF) BE CONDUCTED. ACCOMPLISHMENT OF THE MTF SHALL BE DETERMINED BY THE UNIT MAINTENANCE OFFICER. THE PRE-INSPECTION MTF SHOULD BE CONDUCTED BY A MAINTENANCE TEST PILOT FOLLOWING A REVIEW OF THE AIRCRAFT FORMS AND RECORDS AND A BRIEFING FROM THE CREW OF THE HELICOPTER. THE MTF IS RECOMMENDED TO ASSESS THE HELICOPTER PERFORMANCE AND IDENTIFY DEFICIENCIES THAT SHOULD BE CORRECTED WHILE THE HELICOPTER IS UNDERGOING PHASED MAINTENANCE INSPECTIONS.

PHASE NO. _____		PHASED MAINTENANCE CHECKLIST			
Area Name and No. GENERAL		Aircraft Serial No.		Date	Total Hrs. This Area
Inspect Phase Nos.	Inspection Requirements	Status	Faults and/or Remarks	Action Taken	Initial
ALL C	1. Prior to inspection, check forms and records for record deficiencies (Section 1 Table 1).				
ALL C	2. Fuel tanks will be fully serviced prior to start of phased inspection. If maintenance is to be accomplished which requires defueling, this item may be deferred until after such maintenance is completed.				
ALL	3. Clean Engines IAW TM 55-2840-248-23				
ALL C	4. Perform Oil Samples				
ALL C	5. EXTERIOR SKIN FOR HOLES, CRACKS, DENTS, CORROSION, LOOSE OR MISSING HARDWARE. HANDHOLDS AND STEPS FOR DAMAGE, STRUCTURAL INTEGRITY AND MOUNTING SECURITY.				

“FOD REMINDER”

Check work area for tools and parts after completion of maintenance and inspection.

PHASE NO. _____		PHASED MAINTENANCE CHECKLIST			
Area Name and No. GENERAL		Aircraft Serial No.		Date	Total Hrs. This Area
Inspect Phase Nos.	Inspection Requirements	Status	Faults and/or Remarks	Action Taken	Initial
ALL	6. Remove Pilot and CPG seats. NOTE Ensure the CPG seat has the travel block installed on height adjustment track. This will prevent the seat from causing SSU damage.				
ALL C	7. Depanel Aircraft (See pages 2-4 and 2-5)				
ALL	8. Access panels, fairings and doors for deformation, cracks, corrosion, loose or working rivets, and loose or missing hardware. Door hinges and supports for damage, binding and security. Latches for security and proper operation. Seals for wear or deterioration. Preform packing on camlock fasteners on access panels for deterioration. Aircraft paint for flaking and non-skid surfaces for missing non-skid material.				

“FOD REMINDER”

Check work area for tools and parts after completion of maintenance and inspection.

PHASE NO. _____				PHASED MAINTENANCE CHECKLIST									
Area Name and No. GENERAL				Aircraft Serial No.				Date		Total Hrs. This Area			

Panels for "ALL" Phase Requirements								Additional Panels for Phase 2 & 4			
Panel	Removed	Installed	Inspected	Panel	Removed	Installed	Inspected	Panel	Removed	Installed	Inspected
L40				LN6				T50			
R40				RN1				B105			
B65L				RN6				L115			
B41R				L200				R115			
B60				R200				LN2			
B40R				T250L				LN3			
B65R				T290L				LN4			
L90				T250R				LN5			
L60				T290R				RN2			
L160				L325				RN3			
L140				T205L				RN4			
L175				T205R				RN5			
L194				T225				R230			
R60				R325				L295			
R90				T355				R295			
R140				B90				L330			
R175				B120				R330			
R194				B300				R578			
R160				B80L				T545			
R170				B80R				L550			
R180				B75R				B545			

"FOD REMINDER"

Check work area for tools and parts after completion of maintenance and inspection.

PHASE NO. _____		PHASED MAINTENANCE CHECKLIST						
Area Name and No. GENERAL				Aircraft Serial No.			Date	Total Hrs. This Area

Panels for "ALL" Phase Requirements								Additional Panels for Phase 2 & 4			
Panel	Removed	Installed	Inspected	Panel	Removed	Installed	Inspected	Panel	Removed	Installed	Inspected
LW7				B85R							
LW8				B85L							
LW11				B200							
LW9				B330							
LW10				R410							
P3				R475							
P1				L325							
RW7				R510							
RW8				L510							
RW9				L530							
RW10				L540							
RW11				L545							
LN1				R545							
LS1				RS1							

"FOD REMINDER"

Check work area for tools and parts after completion of maintenance and inspection.

PHASE NO. _____		PHASED MAINTENANCE CHECKLIST			
Area Name and No. FORWARD FUSELAGE – 1		Aircraft Serial No.		Date	Total Hrs. This Area
Inspect Phase Nos.	Inspection Requirements	Status	Faults and/or Remarks	Action Taken	Initial
ALL	1. Interior components for mounting security and loose or missing hardware. Access L40, R40				
ALL	2. Interior structure for cracks, corrosion, loose or working rivets, and loose or missing hardware.				
ALL	3. Avionics equipment for proper stowage, external damage, or loose connectors. Wiring harness for proper clearance, chafing, or deterioration. Especially wire harness W255, as it routes around the BBC.				

“FOD REMINDER”

Check work area for tools and parts after completion of maintenance and inspection.

TM 1-1520-238-PM

PHASE NO. _____		Area Name and No. FORWARD FUSELAGE – 1		Aircraft Serial No.		Date
Inspect Phase Nos.	Inspection Requirements	Status	Faults and/or Remarks	Action Taken		Initial
ALL	4. PNVS captive mounting screws for proper security to azimuth drive gimbal assembly.					
ALL	5. CPG brake master cylinders for leakage, cracks, and loose or missing hardware. Hydraulic lines for leakage and connection security. Access B41R, B60					
ALL C	6. Flight control rods for dents, cracks, corrosion, security, and evidence of interference. Rod ends for looseness. Access B40R, B41R, B60					
ALL C	7. Flight control bellcranks for cracks, corrosion, security, and evidence of interference. Check floating bushing clamp-up and pivot bearings for looseness. Access B40R, B41R, B60, B65L, B65R					

“FOD REMINDER”

Check work area for tools and parts after completion of maintenance and inspection.

TM 1-1520-238-PM

PHASE NO. _____		Area Name and No. FORWARD FUSELAGE – 1		Aircraft Serial No.		Date
Inspect Phase Nos.	Inspection Requirements	Status	Faults and/or Remarks	Action Taken	Initial	
ALL C	8. CPG DECOUPLER (SPAD) UNITS FOR CRACKS, CORROSION, SECURITY, EVIDENCE OF INTERFERENCE, AND FOR LOOSENESS OR LOST MOTION. Access B60					
ALL C	9. CPG DECOUPLER SHEAR PINS FOR DAMAGE OR PARTIAL SHEARING. (BUCS AIRCRAFT ONLY) Access B60					
ALL C	10. PERFORM ADJUSTMENT AND ELECTRICAL CHECK ON CPG DECOUPLER (SPAD) UNITS MICROSWITCHES. (BUCS AIRCRAFT ONLY) Access B60					

“FOD REMINDER”

Check work area for tools and parts after completion of maintenance and inspection.

TM 1-1520-238-PM

PHASE NO. _____		Area Name and No. FORWARD FUSELAGE – 1		Aircraft Serial No.		Date
Inspect Phase Nos.	Inspection Requirements	Status	Faults and/or Remarks	Action Taken	Initial	
ALL C	11. LVDTs for cracks, corrosion, and mounting security. wiring harness for loose connections, chafing, or deterioration and evidence of interference. Rod ends for looseness. Access B40R, B60					
2,4 C	12. WARNING: Do not attempt to move jettison handle. Exterior canopy jettison components for cut or broken transfer tubes, bulged or swollen unions, missing hardware, and torn or missing streamer. Access T50, L40, R40					
2,4	13. Canopy emergency release drain hose and outlets for breaks. Access T50, L40, R40					

“FOD REMINDER”

Check work area for tools and parts after completion of maintenance and inspection.

PHASE NO. _____		PHASED MAINTENANCE CHECKLIST			
Area Name and No. CREW STATIONS – 2		Aircraft Serial No.		Date	Total Hrs. This Area
Inspect Phase Nos.	Inspection Requirements	Status	Faults and/or Remarks	Action Taken	Initial
ALL	1. Interior components for mounting security and loose or missing hardware.				
2,4	2. Interior structure for cracks, corrosion, loose or working rivets, and loose or missing hardware.				
2,4	3. Pilot magnetic brake trim and feel spring units for cracks, corrosion, mounting security, and for looseness or lost motion. Wiring harness for loose connections, chafing, or deterioration.				

“FOD REMINDER”

Check work area for tools and parts after completion of maintenance and inspection.

TM 1-1520-238-PM

PHASE NO. _____		Area Name and No. CREW STATIONS – 2		Aircraft Serial No.	Date
Inspect Phase Nos.	Inspection Requirements	Status	Faults and/or Remarks	Action Taken	Initial
ALL	4. Electrical power distribution box components for mounting security. Wiring harnesses for security, proper connections, chafing, and cleanliness. Remove pilot canted bulkhead cover for access.				
ALL	5. Pilot canted bulkhead for cracks, corrosion, loose or missing hardware, and loose, cracked, or broken seat attach fittings.				
ALL	6. Pilot seat for cracks, distortion, and security. Upholstery and cushions for tears and cleanliness.				

“FOD REMINDER”

Check work area for tools and parts after completion of maintenance and inspection.

TM 1-1520-238-PM

PHASE NO. _____		Area Name and No. CREW STATIONS – 2		Aircraft Serial No.		Date	
Inspect Phase Nos.	Inspection Requirements	Status	Faults and/or Remarks	Action Taken		Initial	
ALL	7. Pilot seat belt and harness straps for cuts, fraying, and cleanliness. Strap fittings for corrosion and security.						
2,4 C	8. Remove and inspect pilot overhead circuit breaker panels for security and loose or missing fasteners. Circuit breakers for looseness or damage. All markings for readability.						
ALL C	9. Pilot cyclic stick for security and worn bushings. Grip switches for damage or looseness. All markings for readability. Base wiring harness for loose connections, chafing, or deterioration. Control linkage for damage, looseness, or evidence of interference.						
ALL C	10. Pilot collective stick for security and worn bushings. Grip switches for damage or looseness. all markings for readability. Base wiring harness for loose connections, chafing, or deterioration. Control linkage for damage, looseness, or evidence of interference.						

“FOD REMINDER”

Check work area for tools and parts after completion of maintenance and inspection.

TM 1-1520-238-PM

PHASE NO. _____		Area Name and No. CREW STATIONS – 2		Aircraft Serial No.		Date		
Inspect Phase Nos.	Inspection Requirements	Status	Faults and/or Remarks	Action Taken		Initial		
ALL C	11. Pilot directional pedals for damage and security. Supports for cracks, bends, or corrosion. Rod assemblies for cracks, corrosion, worn bearings, and loose or missing hardware. Adjusting handle for proper attachment and operation.							
2,4 C	12. Pilot engine power controls for bent, cracked, or broken cable supports and brackets. Rods and rod ends for loose or worn bearings and loose or missing hardware. Check power quadrant detent operation. Remove pilot left console side panels for interior access.							
2,4 C	13. Pilot flight control linkage for cracks, corrosion, and security.							
2,4 C	14. Pilot wiring harnesses for loose or missing hardware, chafed wires, loose connections, and broken tie-wraps. Brackets for damage or corrosion. Remove pilot console side panels for access.							

“FOD REMINDER”

Check work area for tools and parts after completion of maintenance and inspection.

TM 1-1520-238-PM

PHASE NO. _____		Area Name and No. CREW STATIONS – 2		Aircraft Serial No.		Date	
Inspect Phase Nos.	Inspection Requirements	Status	Faults and/or Remarks	Action Taken	Initial		
ALL	15. Pilot SSU mount for strut failure, and loose or missing hardware.						
ALL	16. Pilot cockpit interior for cleanliness.						
2,4 C	17. WARNING: Do not attempt to move jettison handle. Pilot canopy jettison components for cut or broken detonation cords, bulged unions, and loose or missing hardware. Handle safety pin for torn or missing streamer and worn or missing cable.						

“FOD REMINDER”

Check work area for tools and parts after completion of maintenance and inspection.

TM 1-1520-238-PM

PHASE NO. _____		Area Name and No. CREW STATIONS – 2		Aircraft Serial No.	Date
Inspect Phase Nos.	Inspection Requirements	Status	Faults and/or Remarks	Action Taken	Initial
ALL	18. Pilot station upper walkway structure, interior and exterior, for peeling or deterioration.				
ALL	19. CPG seat for cracks, distortion, and security. Upholstery and cushions for tears and cleanliness.				
ALL	20. CPG seat belt and harness straps for cuts, fraying, and cleanliness. Strap fittings for corrosion and security.				

“FOD REMINDER”

Check work area for tools and parts after completion of maintenance and inspection.

PHASE NO. _____		Area Name and No. CREW STATIONS – 2		Aircraft Serial No.		Date	
Inspect Phase Nos.	Inspection Requirements	Status	Faults and/or Remarks	Action Taken		Initial	
ALL C	21. CPG cyclic stick for security and worn bushings. Grip switches for damage or looseness. All markings for readability. Base wiring harness for loose connections, chafing, or deterioration. Control linkage for damage, looseness, or evidence of interference.						
ALL C	22. CPG collective stick for security and worn bushings. Grip switches for damage or looseness. All markings for readability. Base wiring harness for loose connections, chafing, or deterioration. Control linkage for damage, looseness, or evidence of interference.						
ALL C	23. CPG directional pedals for damage and security. Supports for cracks, bends or corrosion. Rod assembly for cracks, corrosion, worn bearings, and loose or missing hardware. Adjusting handle for proper attachment and operation.						

“FOD REMINDER”

Check work area for tools and parts after completion of maintenance and inspection.

TM 1-1520-238-PM

PHASE NO. _____		Area Name and No. CREW STATIONS – 2		Aircraft Serial No.		Date		
Inspect Phase Nos.	Inspection Requirements	Status	Faults and/or Remarks	Action Taken		Initial		
2,4 C	24. CPG engine power controls for bent, cracked, or broken cable supports and brackets. Rods and rod ends for loose or worn bearings and loose or missing hardware. Check power quadrant detent operation. Remove CPG left console side panels for interior access.							
2,4 C	25. CPG flight control linkage for cracks, corrosion, and security. Remove floor panels for access.							
2,4 C	26. CPG wiring harness for loose or missing hardware, chafed wires, loose connections, and broken tie-wraps. Brackets for damage or corrosion. Remove CPG console side panels for access.							
ALL	27. CPG SSU mount for strut failure, and loose or missing hardware.							

“FOD REMINDER”

Check work area for tools and parts after completion of maintenance and inspection.

TM 1-1520-238-PM

PHASE NO. _____		Area Name and No. CREW STATIONS – 2		Aircraft Serial No.		Date	
Inspect Phase Nos.	Inspection Requirements	Status	Faults and/or Remarks	Action Taken		Initial	
ALL	28. CPG cockpit interior for cleanliness.						
2,4 C	29. WARNING: Do not attempt to move jettison handle. CPG canopy jettison components for cut or broken detonation cords, bulged unions, and loose or missing hardware. Handle for torn or missing streamer and worn or missing cable.						
ALL	30. Pilot brake master cylinders for leakage, cracks, and loose or missing hardware. Hydraulic lines for leakage and connection security.						
2,4	31. Canopy vent for deteriorated or missing seals, missing connecting rod pins, and loose or working rivets.						

“FOD REMINDER”

Check work area for tools and parts after completion of maintenance and inspection.

PHASE NO. _____		PHASED MAINTENANCE CHECKLIST			
Area Name and No. LEFT FORWARD AVIONICS BAY AND MLG – 3		Aircraft Serial No.		Date	Total Hrs. This Area
Inspect Phase Nos.	Inspection Requirements	Status	Faults and/or Remarks	Action Taken	Initial
ALL C	1. Avionics bay door and mating structural surface for missing, non-adhering, or worn chafe tape/EMI coating. Access L90				
ALL	2. Interior components for mounting security and loose or missing hardware.				
ALL	3. Interior structure for cracks, corrosion, loose or working rivets, and loose or missing hardware.				

“FOD REMINDER”

Check work area for tools and parts after completion of maintenance and inspection.

TM 1-1520-238-PM

PHASE NO. _____		Area Name and No. LEFT FORWARD AVIONICS BAY AND MLG – 3		Aircraft Serial No.		Date
Inspect Phase Nos.	Inspection Requirements	Status	Faults and/or Remarks	Action Taken	Initial	
ALL	4. Avionics equipment for proper stowage, external damage, or loose connectors. Wiring harness for chafing or deterioration. Access L60, L90					
ALL	5. Mounting racks for distortion, loose or missing fasteners. Cooling ducts for cracks or distortion, proper fit, and evidence of leakage. Access L60, L90					
ALL	6. Avionics bay for cleanliness and distortion. Access L60, L90, L140, L175, L194. Step must be removed from L175 prior to removal.					
ALL C	REMOVE MAIN GEAR SHOCK STRUT. INSPECT FROM THE BASE OF THE MOUNT TO THE END OF THE SHAFT. INSPECT FOR PITS, GROOVES AND SCRATCHES, AND FOR CRACKS USING NDI INSPECTION. CHECK FOR DISTORTION, OR LOOSENESS, LOOSE OR MISSING RIVETS OR FASTENERS.					

“FOD REMINDER”

Check work area for tools and parts after completion of maintenance and inspection.

TM 1-1520-238-PM

PHASE NO. _____		Area Name and No. LEFT FORWARD AVIONICS BAY AND MLG – 3		Aircraft Serial No.		Date		
Inspect Phase Nos.	Inspection Requirements	Status	Faults and/or Remarks	Action Taken		Initial		
2,4 C	8. MLG trailing arm for cracks, distortion, or corrosion. Cross tube end pivot boss for security, damaged or worn bearing, loose or missing hardware. Hydraulic brake line for leakage, dents, corrosion, and clamping security. Access L115							
ALL C	9. MLG end cap for cracks, distortion, fractured weld, and elongated bolt holes.							
ALL C	10. MLG SHOCK STRUT UPPER AND LOWER ROD ENDS FOR BEARING DAMAGE.							
2,4 C	11. MLG wheel for cracks, distortion, or corrosion. Hub for grease leakage. Tire for tread damage or uneven wear.							

“FOD REMINDER”

Check work area for tools and parts after completion of maintenance and inspection.

TM 1-1520-238-PM

PHASE NO. _____		Area Name and No. LEFT FORWARD AVIONICS BAY AND MLG – 3		Aircraft Serial No.		Date
Inspect Phase Nos.	Inspection Requirements	Status	Faults and/or Remarks	Action Taken	Initial	
2,4 C	12. Repack MLG wheel bearings. Check for smooth operation.					
2,4 C	13. MLG wheel keys for wear.					
2,4 C	14. MLG wheel brake for fluid leakage, cracked housing, or corrosion. Brake disk and lining for wear. Hydraulic lines for leakage and connection security.					
2,4	15. MLG wheel brake key slots for damage or wear.					
2,4	16. MLG jack-tow pad and step for corrosion, cracks, and mounting security.					

“FOD REMINDER”

Check work area for tools and parts after completion of maintenance and inspection.

TM 1-1520-238-PM

PHASE NO. _____		Area Name and No. LEFT FORWARD AVIONICS BAY AND MLG – 3		Aircraft Serial No.		Date	
Inspect Phase Nos.	Inspection Requirements	Status	Faults and/or Remarks	Action Taken		Initial	
2,4	17. Squat switch for deformation, damaged insulation, loose connections, and mounting security. Wiring harness for chafing or deterioration. Access L115, L140						
ALL	18. Inspect forward fuel cell and pilot's collective bellcrank for chafing and/or interference with flight controls, structural deterioration, security, and damage to host helicopter. (Not required if restraint panel is installed IAW TB 1-1520-238-20-53) Access L160						
ALL C	19. Pilot collective push-pull rods for corrosion, bending, worn, bound, or seized bearings, loose or missing hardware, and evidence of interference. Access L160						
ALL C	20. Pilot collective bellcrank for cracks, corrosion, and bound or seized bearings. Support for cracks, corrosion, worn bearings, loose or missing hardware, and evidence of interference. Access L160						

“FOD REMINDER”

Check work area for tools and parts after completion of maintenance and inspection.

PHASE NO. _____		PHASED MAINTENANCE CHECKLIST			
Area Name and No. RIGHT FORWARD AVIONICS BAY AND MLG – 4		Aircraft Serial No.		Date	Total Hrs. This Area
Inspect Phase Nos.	Inspection Requirements	Status	Faults and/or Remarks	Action Taken	Initial
ALL C	1. Avionics bay door and mating structural surface for missing, non-adhering, or worn chafe tape/EMI coating. Access R90				
ALL	2. Interior components for mounting security and loose or missing hardware.				
ALL	3. Interior structure for cracks, corrosion, loose or working rivets, and loose or missing hardware.				

“FOD REMINDER”

Check work area for tools and parts after completion of maintenance and inspection.

TM 1-1520-238-PM

PHASE NO. _____		Area Name and No. RIGHT FORWARD AVIONICS BAY AND MLG – 4		Aircraft Serial No.		Date	
Inspect Phase Nos.	Inspection Requirements	Status	Faults and/or Remarks	Action Taken		Initial	
ALL	4. Avionics equipment for proper stowage, external damage, or loose connectors. Wiring harness for chafing or deterioration. Access R60, R90						
ALL	5. Mounting racks for distortion and loose or missing fasteners. Cooling ducts for cracks or distortion, proper fit, and evidence of leakage. Access R60, R90						
ALL	6. Avionics bay for cleanliness and distortion. Access R60, R90, R140, R175, R194. Step must be removed from R175 prior to removal.						
ALL C	REMOVE MAIN GEAR SHOCK STRUT. INSPECT FROM THE BASE OF THE MOUNT TO THE END OF THE SHAFT. INSPECT FOR PITS, GROOVES AND SCRATCHES AND FOR CRACKS USING NDI INSPECTION. CHECK FOR DISTORTION, OR LOOSENESS, LOOSE OR MISSING RIVETS OR FASTENERS.						

“FOD REMINDER”

Check work area for tools and parts after completion of maintenance and inspection.

TM 1-1520-238-PM

PHASE NO. _____		Area Name and No. RIGHT FORWARD AVIONICS BAY AND MLG – 4		Aircraft Serial No.		Date		
Inspect Phase Nos.	Inspection Requirements	Status	Faults and/or Remarks	Action Taken		Initial		
2,4 C	8. MLG trailing arm for cracks, distortion, or corrosion. Cross tube end pivot boss for security, damaged or worn bearing, loose or missing hardware. Hydraulic brake line for leakage, dents, corrosion, and clamping security. Access R115							
ALL C	9. MLG end cap for cracks, distortion, fractured weld, elongated bolt holes.							
ALL C	10. MLG SHOCK STRUT UPPER AND LOWER ROD ENDS FOR BEARING DAMAGE.							
2,4 C	11. MLG wheel for cracks, distortion, or corrosion. Hub for grease leakage. Tire for tread damage or uneven wear.							

“FOD REMINDER”

Check work area for tools and parts after completion of maintenance and inspection.

TM 1-1520-238-PM

PHASE NO. _____		Area Name and No. RIGHT FORWARD AVIONICS BAY AND MLG – 4		Aircraft Serial No.		Date
Inspect Phase Nos.	Inspection Requirements	Status	Faults and/or Remarks	Action Taken	Initial	
2,4 C	12. Repack MLG wheel bearings. Check for smooth operation.					
2,4 C	13. MLG wheel keys for wear.					
2,4 C	14. MLG wheel brake for fluid leakage, cracked housing, or corrosion. Brake disk and lining for wear. Hydraulic lines for leakage and connection security.					
2,4	15. MLG wheel brake key slots for damage or wear.					
2,4	16. MLG jack-tow pad and step for corrosion, cracks, and mounting security.					

“FOD REMINDER”

Check work area for tools and parts after completion of maintenance and inspection.

TM 1-1520-238-PM

PHASE NO. _____		Area Name and No. RIGHT FORWARD AVIONICS BAY AND MLG – 4		Aircraft Serial No.		Date	
Inspect Phase Nos.	Inspection Requirements	Status	Faults and/or Remarks	Action Taken		Initial	
ALL C	17. Fire extinguisher for charge condition, seal, and stowage security in designated area.						
ALL	18. Refuel control panel for cracks, corrosion, loose or missing hardware, and security of components. All markings for readability. Access R160						
ALL C	19. Gravity fuel fill cap for leakage and proper closure function. Cap packing for cracks, damage, or distortion.						
ALL C	20. Pressure refuel SPA and CCR caps for leakage and full closure. Cap seals for cracks, damage, or distortion.						
ALL	21. Extend searchlight. Check for corrosion, loose or missing fasteners, and security. Lens for cracks or evidence of overheating. Wiring for loose connections, chafing, deterioration, and security.						

“FOD REMINDER”

Check work area for tools and parts after completion of maintenance and inspection.

PHASE NO. _____		PHASED MAINTENANCE CHECKLIST			
Area Name and No. LEFT WING AND PYLONS – 5		Aircraft Serial No.		Date	Total Hrs. This Area
Inspect Phase Nos.	Inspection Requirements	Status	Faults and/or Remarks	Action Taken	Initial
ALL	1. Interior components for mounting security and loose or missing hardware. Access LW7, LW8				
ALL	2. Interior structure for cracks, corrosion, loose or working rivets, and loose or missing hardware. Access LW7, LW8				
ALL C	3. Lower wing mount fittings for cracks or distortion. Mounting bolts for security. Access LW11				
ALL	4. Pylon mounting surfaces and lower wing skin for evidence of hydraulic fluid or fuel leakage.				

“FOD REMINDER”

Check work area for tools and parts after completion of maintenance and inspection.

TM 1-1520-238-PM

PHASE NO. _____		Area Name and No. LEFT WING AND PYLONS – 5		Aircraft Serial No.		Date	
Inspect Phase Nos.	Inspection Requirements	Status	Faults and/or Remarks	Action Taken		Initial	
ALL	5. Pylon connector wiring harness for security, chafing, and loose connections. Hydraulic and fuel lines for security and leakage.						
ALL	6. Hydraulic lines and couplings for leakage and mounting security. Access LW7, LW8, LW9, LW10, LW11						
ALL	7. Wiring harnesses for security and proper connection.						
ALL C	8. Navigation, anti-collision and formation lights for corrosion, loose or missing fasteners, and security. Lenses for cracks, looseness, or discoloration. Wiring harness for chafing and clamping security.						

“FOD REMINDER”

Check work area for tools and parts after completion of maintenance and inspection.

TM 1-1520-238-PM

PHASE NO. _____		Area Name and No. LEFT WING AND PYLONS – 5		Aircraft Serial No.		Date
Inspect Phase Nos.	Inspection Requirements	Status	Faults and/or Remarks	Action Taken	Initial	
ALL C	9. Installed pylons and racks for cracks, dents, distortion, and loose or missing fasteners. Pylon and rack mount fittings for cracks or distortion. Mounting bolts for security.					
ALL	10. Pylon aft fairings and actuators for evidence of hydraulic fluid leakage.					
2,4	11. Spar for cracks, corrosion, and loose or working rivets. Hydraulic lines for leakage and clamping security. Wiring harness for chafing and clamping security. Remove wing trailing edge for access.					

“FOD REMINDER”

Check work area for tools and parts after completion of maintenance and inspection.

TM 1-1520-238-PM

PHASE NO. _____		Area Name and No. LEFT WING AND PYLONS – 5		Aircraft Serial No.		Date
Inspect Phase Nos.	Inspection Requirements	Status	Faults and/or Remarks	Action Taken	Initial	
2,4 C	12. Pitot/static lines for cracks, chafing, and mounting security. Remove wing trailing edge for access.					
ALL	13. Pylon actuator controller brackets for cracks, corrosion, or warping. Access P3					
ALL	14. Pylon station director bracket for cracks, corrosion, or warping. Access P1					

“FOD REMINDER”

Check work area for tools and parts after completion of maintenance and inspection.

TM 1-1520-238-PM

PHASE NO. _____		Area Name and No. LEFT WING AND PYLONS – 5		Aircraft Serial No.		Date	
Inspect Phase Nos.	Inspection Requirements	Status	Faults and/or Remarks	Action Taken		Initial	
ALL	15. Pylon MUX unit bracket for cracks, corrosion, or warping. Access P3						
ALL C	16. Pylon ejector assembly for corroded piston and cartridge holder.						
ALL C	17. Upper wing mount fittings for cracks or distortion. Mounting bolts for security. Access LW10						

“FOD REMINDER”

Check work area for tools and parts after completion of maintenance and inspection.

PHASE NO. _____		PHASED MAINTENANCE CHECKLIST			
Area Name and No. RIGHT WING AND PYLONS – 6		Aircraft Serial No.		Date	Total Hrs. This Area
Inspect Phase Nos.	Inspection Requirements	Status	Faults and/or Remarks	Action Taken	Initial
ALL	1. Interior components for mounting security and loose or missing hardware. Access RW7, RW8				
ALL	2. Interior structure for cracks, corrosion, loose or working rivets, and loose or missing hardware. Access RW7, RW8				
ALL C	3. Lower wing mount fittings for cracks or distortion. Mounting bolts for security. Access RW11				
ALL	4. Pylon mounting surfaces and lower wing skin for evidence of hydraulic fluid or fuel leakage.				

“FOD REMINDER”

Check work area for tools and parts after completion of maintenance and inspection.

TM 1-1520-238-PM

PHASE NO. _____		Area Name and No. RIGHT WING AND PYLONS – 6		Aircraft Serial No.		Date	
Inspect Phase Nos.	Inspection Requirements	Status	Faults and/or Remarks	Action Taken		Initial	
ALL	5. Pylon connector wiring harness for security, chafing, and loose connections. Hydraulic and fuel lines for security and leakage.						
ALL	6. Hydraulic lines and couplings for leakage and mounting security. Access RW7, RW8, RW9, RW10, RW11						
ALL	7. Wiring harnesses for security and proper connection.						
ALL C	8. Navigation, anti-collision and formation lights for corrosion, loose or missing fasteners, and security. Lenses for cracks, looseness, or discoloration. Wiring harness for chafing and clamping security.						

“FOD REMINDER”

Check work area for tools and parts after completion of maintenance and inspection.

TM 1-1520-238-PM

PHASE NO. _____		Area Name and No. RIGHT WING AND PYLONS – 6		Aircraft Serial No.		Date
Inspect Phase Nos.	Inspection Requirements	Status	Faults and/or Remarks	Action Taken	Initial	
ALL C	9. Installed pylons and racks for cracks, dents, distortion, and loose or missing fasteners. Pylon and rack mount fittings for cracks or distortion. Mounting bolts for security.					
ALL	10. Pylon aft fairings and actuators for evidence of hydraulic fluid leakage.					
2,4	11. Spar for cracks, corrosion, and loose or working rivets. Hydraulic lines for leakage and clamping security. Wiring harness for chafing and clamping security. Remove wing trailing edge for access.					

“FOD REMINDER”

Check work area for tools and parts after completion of maintenance and inspection.

TM 1-1520-238-PM

PHASE NO. _____		Area Name and No. RIGHT WING AND PYLONS – 6		Aircraft Serial No.		Date
Inspect Phase Nos.	Inspection Requirements	Status	Faults and/or Remarks	Action Taken	Initial	
2,4 C	12. Pitot/static lines for cracks, chafing, and mounting security. Remove wing trailing edge for access.					
ALL	13. Pylon actuator controller bracket for cracks, corrosion, or warping. Access P3					
ALL	14. Pylon station director bracket for cracks, corrosion, or warping. Access P1					

“FOD REMINDER”

Check work area for tools and parts after completion of maintenance and inspection.

TM 1-1520-238-PM

PHASE NO. _____		Area Name and No. RIGHT WING AND PYLONS – 6		Aircraft Serial No.		Date	
Inspect Phase Nos.	Inspection Requirements	Status	Faults and/or Remarks	Action Taken		Initial	
ALL	15. Pylon MUX unit bracket for cracks, corrosion, or warping. Access P3						
ALL C	16. Pylon ejector assembly for corroded piston and cartridge holder.						
ALL	17. Upper wing mount fittings for cracks or distortion. Mounting bolts for security. Access RW10						

“FOD REMINDER”

Check work area for tools and parts after completion of maintenance and inspection.

PHASE NO. _____		PHASED MAINTENANCE CHECKLIST			
Area Name and No. LEFT ENGINE AND NOSE GEARBOX – 7		Aircraft Serial No.		Date	Total Hrs. This Area
Inspect Phase Nos.	Inspection Requirements	Status	Faults and/or Remarks	Action Taken	Initial
ALL	1. IR suppressor nozzle fairing and mating surface for worn, non-adhering, or missing chafe tape.				
ALL	2. Interior components for mounting security and loose or missing hardware.				
ALL	3. Interior structure for cracks, corrosion, loose or working rivets, and loose or missing hardware.				
ALL C	4. Engine air inlet fairing for cracks, distortion, security, and interior for cleanliness.				

“FOD REMINDER”

Check work area for tools and parts after completion of maintenance and inspection.

TM 1-1520-238-PM

PHASE NO. _____		Area Name and No. LEFT ENGINE AND NOSE GEARBOX – 7		Aircraft Serial No.	Date
Inspect Phase Nos.	Inspection Requirements	Status	Faults and/or Remarks	Action Taken	Initial
2,4 C	5. Particle separator duct for cracks, dents, and deformation. Clamps, mounting pins, clips, and hardware for security. Access LN1				
2,4	6. IR suppressor nozzles and radiation shields for cracks, dents, deformation, and security. Supports for deformation or looseness. Check fins for looseness.				
2,4	7. Engine cooling louvers for cracks, deformation, delamination, distortion, broken, and loose or working rivets. Louver plates for looseness or lost motion. Access L230				

“FOD REMINDER”

Check work area for tools and parts after completion of maintenance and inspection.

TM 1-1520-238-PM

PHASE NO. _____		Area Name and No. LEFT ENGINE AND NOSE GEARBOX – 7		Aircraft Serial No.		Date	
Inspect Phase Nos.	Inspection Requirements	Status	Faults and/or Remarks	Action Taken		Initial	
2,4	8. Fuel valves for leakage, cracks, loose connections, and security. Access LN1						
2,4	9. Fuel and oil lines for leakage, chafing, and security. Access LN1						
2,4	10. Fuel and oil pressure switches for damaged insulation, loose connections, and security. Access LN1						
2,4 C	11. Engine air inlet for cracks, corrosion, deteriorated, torn, or split seals, and loose or working rivets or screws. Ice detector support for broken or missing grommet. Access LN1						

“FOD REMINDER”

Check work area for tools and parts after completion of maintenance and inspection.

TM 1-1520-238-PM

PHASE NO. _____		Area Name and No. LEFT ENGINE AND NOSE GEARBOX – 7		Aircraft Serial No.		Date
Inspect Phase Nos.	Inspection Requirements	Status	Faults and/or Remarks	Action Taken	Initial	
2,4	12. Drain and service engine starter. Check for cracked, worn, or loose clamps, and loose or missing hardware. Access LN1					
2,4	13. Engine wiring harness for loose connections, chafing, or deterioration. Access LN1					
2,4 C	14. Engine power control cables and brackets for cracks, corrosion, mounting security, and loose or missing hardware. Access LN1					

“FOD REMINDER”

Check work area for tools and parts after completion of maintenance and inspection.

TM 1-1520-238-PM

PHASE NO. _____		Area Name and No. LEFT ENGINE AND NOSE GEARBOX – 7		Aircraft Serial No.		Date	
Inspect Phase Nos.	Inspection Requirements	Status	Faults and/or Remarks	Action Taken		Initial	
ALL C	15. Primary exhaust nozzle for cracks, holes, or broken welds.						
ALL C	16. Engine case for cracks. Access LN1						
2,4 C	17. Engine mounts for cracks, deformation, loose bushings, corrosion, security, and loose or missing hardware. Pins and expanding bolts for fractures, wear, and looseness. (ENGINE REMOVED) Access LN1, LN2, LN3, LN4, LN5						
ALL	18. V-band clamps for security. Access LN1						

“FOD REMINDER”

Check work area for tools and parts after completion of maintenance and inspection.

TM 1-1520-238-PM

PHASE NO. _____		Area Name and No. LEFT ENGINE AND NOSE GEARBOX – 7		Aircraft Serial No.		Date	
Inspect Phase Nos.	Inspection Requirements	Status	Faults and/or Remarks	Action Taken		Initial	
2,4	19. Engine drain lines for leakage, tube or hose failure, and loose or missing clamps or hardware. Access LN1, LN2						
ALL	20. Nose gearbox wiring for loose connections, chafing, or deterioration. Access LN6						
ALL C	21. Remove and clean nose gearbox chip detector. Check for insulation damage. Check chip detector operation. Access LN6						
ALL C	22. Remove and clean nose gearbox breather. Access LN6						

“FOD REMINDER”

Check work area for tools and parts after completion of maintenance and inspection.

TM 1-1520-238-PM

PHASE NO. _____		Area Name and No. LEFT ENGINE AND NOSE GEARBOX – 7		Aircraft Serial No.		Date	
Inspect Phase Nos.	Inspection Requirements	Status	Faults and/or Remarks	Action Taken		Initial	
ALL C	23. Change nose gearbox lube oil and filter. Access LN6						
ALL	24. Nose gearbox oil pressure switch, pressure transducer, and temperature probe for insulation damage, oil leakage, and security. Harness splices for security. Access LN6						
ALL	25. Nose gearbox lube oil level sight gage for cleanliness, leakage, and security. Clean lens.						
ALL C	26. Nose gearbox and lube oil pump housings for cracks, distortion, leakage and security. Access LN6						

“FOD REMINDER”

Check work area for tools and parts after completion of maintenance and inspection.

TM 1-1520-238-PM

PHASE NO. _____		Area Name and No. LEFT ENGINE AND NOSE GEARBOX – 7		Aircraft Serial No.		Date	
Inspect Phase Nos.	Inspection Requirements	Status	Faults and/or Remarks	Action Taken		Initial	
2,4 C	27. Nose gearbox mounting bolts for proper installation and torque. Access LN6						
2,4 C	28. Nose gearbox cooling fan and shroud for cracks, deformation, corrosion, and security. Fan impeller for erosion or damage. Access LN6						
ALL C	29. Nose gearbox drive shaft and couplings for nicks, dents, scratches, and security.						
2,4 C	30. Perform Engine Periodic Inspection (TM 55-2840-248-23)						

“FOD REMINDER”

Check work area for tools and parts after completion of maintenance and inspection.

PHASE NO. _____		PHASED MAINTENANCE CHECKLIST			
Area Name and No. RIGHT ENGINE AND NOSE GEARBOX – 8		Aircraft Serial No.		Date	Total Hrs. This Area
Inspect Phase Nos.	Inspection Requirements	Status	Faults and/or Remarks	Action Taken	Initial
ALL	1. IR suppressor nozzle fairing and mating surface for worn, non-adhering, or missing chafe tape.				
ALL	2. Interior components for mounting security and loose or missing hardware.				
ALL	3. Interior structure for cracks, corrosion, loose or working rivets, and loose or missing hardware.				
ALL C	4. Engine air inlet fairing for cracks, distortion, security, and interior for cleanliness.				

“FOD REMINDER”

Check work area for tools and parts after completion of maintenance and inspection.

TM 1-1520-238-PM

PHASE NO. _____		Area Name and No. RIGHT ENGINE AND NOSE GEARBOX – 8		Aircraft Serial No.		Date	
Inspect Phase Nos.	Inspection Requirements	Status	Faults and/or Remarks	Action Taken		Initial	
2,4 C	5. Particle separator duct for cracks, dents, and deformation. Clamps, mounting pins, clips, and hardware for security. Access RN1						
2,4	6. IR suppressor nozzles and radiation shields for cracks, dents, deformation, and security. Supports for deformation or looseness. Fins for looseness.						
2,4	7. Engine cooling louvers for cracks, deformation, distortion, broken, and loose or working rivets. Louver plates for looseness or lost motion. Access R230						

“FOD REMINDER”

Check work area for tools and parts after completion of maintenance and inspection.

TM 1-1520-238-PM

PHASE NO. _____		Area Name and No. RIGHT ENGINE AND NOSE GEARBOX – 8		Aircraft Serial No.		Date	
Inspect Phase Nos.	Inspection Requirements	Status	Faults and/or Remarks	Action Taken		Initial	
2,4	8. Fuel valves for leakage, cracks, loose connections, and security. Access RN1						
2,4	9. Fuel and oil lines for leakage, chafing, and security. Access RN1						
2,4	10. Fuel and oil pressure switches for damaged insulation, loose connections, and security. Access RN1						
2,4 C	11. Engine air inlet for cracks, corrosion, deteriorated, torn, or split seals, and loose or working rivets or screws. Ice detector support for broken or missing grommet. Access RN1						

“FOD REMINDER”

Check work area for tools and parts after completion of maintenance and inspection.

TM 1-1520-238-PM

PHASE NO. _____		Area Name and No. RIGHT ENGINE AND NOSE GEARBOX – 8		Aircraft Serial No.		Date
Inspect Phase Nos.	Inspection Requirements	Status	Faults and/or Remarks	Action Taken		Initial
2,4	12. Drain and service engine starter. Check for cracked, worn, or loose clamps, and loose or missing hardware. Access RN1.					
2,4	13. Engine wiring harness for loose connections, chafing, or deterioration. Access RN1.					
2,4 C	14. Engine power control cables and brackets for cracks, corrosion, mounting security, and loose or missing hardware. Access RN1.					

“FOD REMINDER”

Check work area for tools and parts after completion of maintenance and inspection.

TM 1-1520-238-PM

PHASE NO. _____		Area Name and No. RIGHT ENGINE AND NOSE GEARBOX – 8		Aircraft Serial No.		Date	
Inspect Phase Nos.	Inspection Requirements	Status	Faults and/or Remarks	Action Taken		Initial	
ALL C	15. Primary exhaust nozzle for cracks, holes, or broken welds.						
ALL C	16. Engine case for cracks. Access RN1						
2,4 C	17. Engine mounts for cracks, deformation, loose bushings, corrosion, security, and loose or missing hardware. Pins and expanding bolts for fractures, wear, and looseness. (ENGINE REMOVED) Access RN1, RN2, RN3, RN4, RN5						
ALL	18. V-band clamps for security. Access RN1						

“FOD REMINDER”

Check work area for tools and parts after completion of maintenance and inspection.

TM 1-1520-238-PM

PHASE NO. _____		Area Name and No. RIGHT ENGINE AND NOSE GEARBOX – 8		Aircraft Serial No.		Date
Inspect Phase Nos.	Inspection Requirements	Status	Faults and/or Remarks	Action Taken	Initial	
2,4	19. Engine drain lines for leakage, tube or hose failure, and loose or missing clamps or hardware. Access RN1, RN2					
ALL	20. Nose gearbox wiring for loose connections, chafing, or deterioration. Access RN6					
ALL C	21. Remove and clean nose gearbox chip detector. Check for insulation damage. Check chip detector operation. Access RN6					
ALL C	22. Remove and clean nose gearbox breather. Access RN6					

“FOD REMINDER”

Check work area for tools and parts after completion of maintenance and inspection.

TM 1-1520-238-PM

PHASE NO. _____		Area Name and No. RIGHT ENGINE AND NOSE GEARBOX – 8		Aircraft Serial No.		Date	
Inspect Phase Nos.	Inspection Requirements	Status	Faults and/or Remarks	Action Taken		Initial	
ALL C	23. Change nose gearbox lube oil and filter. Access RN6						
ALL	24. Nose gearbox oil pressure switch, pressure transducer, and temperature probe for insulation damage, oil leakage, and security. Harness splices for security. Access RN6						
ALL	25. Nose gearbox lube oil level sight gage for cleanliness, leakage, and security. Clean lens.						
ALL C	26. Nose gearbox and lube oil pump housings for cracks, distortion, leakage, and security. Access RN6						

“FOD REMINDER”

Check work area for tools and parts after completion of maintenance and inspection.

TM 1-1520-238-PM

PHASE NO. _____		Area Name and No. RIGHT ENGINE AND NOSE GEARBOX – 8		Aircraft Serial No.		Date
Inspect Phase Nos.	Inspection Requirements	Status	Faults and/or Remarks	Action Taken	Initial	
2,4 C	27. Nose gearbox mounting bolts for proper installation and torque. Access RN6					
2,4 C	28. Nose gearbox cooling fan and shroud for cracks, deformation, corrosion, and security. Fan impeller for erosion or damage. Access RN6					
ALL C	29. Nose gearbox drive shaft and couplings for nicks, dents, scratches, and security.					
2,4 C	30. Perform Engine Periodic Inspection (TM 55-2840-248-23).					

“FOD REMINDER”

Check work area for tools and parts after completion of maintenance and inspection.

PHASE NO. _____		PHASED MAINTENANCE CHECKLIST			
Area Name and No. MAIN TRANSMISSION – 9		Aircraft Serial No.		Date	Total Hrs. This Area
Inspect Phase Nos.	Inspection Requirements	Status	Faults and/or Remarks	Action Taken	Initial
ALL	1. Interior components for mounting security and loose or missing hardware.				
ALL	2. Interior structure for cracks, corrosion, loose or working rivets, and loose or missing hardware.				
ALL	3. Transmission housing and cover for cracks, oil leakage, and evidence of overheating (discoloration). Torque check upper case nuts. Access L200, R200				

“FOD REMINDER”

Check work area for tools and parts after completion of maintenance and inspection.

TM 1-1520-238-PM

PHASE NO. _____		Area Name and No. MAIN TRANSMISSION – 9		Aircraft Serial No.		Date	
Inspect Phase Nos.	Inspection Requirements	Status	Faults and/or Remarks	Action Taken		Initial	
ALL C	4. Remove and clean chip detectors. Check for insulation and operation. Access L200, R200						
2,4	5. Wiring harnesses for loose connections, chafing, or deterioration. Access L200, R200						
ALL C	6. Replace accessory pump oil filter. Remove and clean bypass screen. Access T250L, T290L, T250R, T290R, L325, R200						
ALL	7. Hydraulic and lube oil lines for cracks, leakage, chafing, and security. Access L200, R200						

“FOD REMINDER”

Check work area for tools and parts after completion of maintenance and inspection.

TM 1-1520-238-PM

PHASE NO. _____		Area Name and No. MAIN TRANSMISSION – 9		Aircraft Serial No.		Date
Inspect Phase Nos.	Inspection Requirements	Status	Faults and/or Remarks	Action Taken	Initial	
2,4 C	8. Clean breathers. Access L200, R200					
ALL C	9. Change lube oil and filters. Access L200, R200					
2,4	10. Oil pressure switches, pressure transducers, temperature probes, and magnetic pickup for insulation damage, leakage, and security. Harness splices for security. Access L200, R200					
ALL	11. Lube oil level sight gages for cleanliness, leakage, and security. Clean lenses. Access L200, R200					

“FOD REMINDER”

Check work area for tools and parts after completion of maintenance and inspection.

TM 1-1520-238-PM

PHASE NO. _____		Area Name and No. MAIN TRANSMISSION – 9		Aircraft Serial No.		Date	
Inspect Phase Nos.	Inspection Requirements	Status	Faults and/or Remarks	Action Taken		Initial	
ALL C	12. Input shafts, couplings, and drive flanges for cracks, dents, distortion, and corrosion. Access L200, R200, LN6, RN6						
2,4 C	13. Input shaft and coupling bolts for proper installation. Access L200, R200, LN6, RN6						
ALL C	14. Primary hydraulic manifold for leakage, corrosion, loose connections, and security. Sight gage for proper fluid level. Check manifold air inlet check valve filter for cleanliness. Access L200						
ALL C	15. Generators for cleanliness and fod, smooth and easy rotation. Spline gear and adapter for damage and wear. Gen seal for leakage. Access L200, R200						

“FOD REMINDER”

Check work area for tools and parts after completion of maintenance and inspection.

TM 1-1520-238-PM

PHASE NO. _____		Area Name and No. MAIN TRANSMISSION – 9		Aircraft Serial No.		Date	
Inspect Phase Nos.	Inspection Requirements	Status	Faults and/or Remarks	Action Taken	Initial		
ALL C	16. Generators for damaged insulation, security, and cracked or broken housings. Access L200, R200						
ALL	17. Hydraulic pumps for leakage, loose connections, and security. Access L200, R200						
2,4	18. Transformer/rectifiers for evidence of overheating (discoloration) and security. Access L200						
ALL C	19. Anti-collision light power supply for corrosion and loose or missing hardware. Access L200						

“FOD REMINDER”

Check work area for tools and parts after completion of maintenance and inspection.

TM 1-1520-238-PM

PHASE NO. _____		Area Name and No. MAIN TRANSMISSION – 9		Aircraft Serial No.		Date		
Inspect Phase Nos.	Inspection Requirements	Status	Faults and/or Remarks	Action Taken		Initial		
ALL C	20. Flight control servocylinders for leakage, cracks, or corrosion. Upper and lower rod ends for bearing damage and security. Inspect servocylinder control linkage fasteners for damage and security. Access L200, R200							
2,4 C	21. Inspect and clean flight control servocylinders pressure filter. Access L200, R200							
ALL C	22. Main rotor mast support struts for cracks, bending, distortion, and security. Transmission deck for distortion or looseness at lower ends of struts. Access L200, R200							
ALL C	23. Mast base for cracks, distortion, and security. Mast support mount and upper ends of support struts for looseness. Inspect the upper portion of the mast base support in the areas around the four lightening holes, mast and mixer supports for corrosion. Access L200, R200							

“FOD REMINDER”

Check work area for tools and parts after completion of maintenance and inspection.

TM 1-1520-238-PM

PHASE NO. _____		Area Name and No. MAIN TRANSMISSION – 9		Aircraft Serial No.		Date		
Inspect Phase Nos.	Inspection Requirements	Status	Faults and/or Remarks	Action Taken		Initial		
2,4 C	24. STATIC MAST SUPPORT BASE AND MIXER SUPPORTS FOR CORROSION. Mixer supports for cracks, distortion, and corrosion. Mixer attachment bolts for cracks, corrosion and security. Bearings for excessive play. (Mast Base and Mixer Supports removed) Access L200, R200							
ALL C	25. Flight control rods for dents, cracks, corrosion, security, and worn or seized bearings and bushings. Rod ends for looseness. Access L200, R200							
2,4 C	26. Flight control bellcranks for cracks, corrosion, and security. Brackets for mounting security. Pivot bearings for looseness. Access L200, R200							

“FOD REMINDER”

Check work area for tools and parts after completion of maintenance and inspection.

TM 1-1520-238-PM

PHASE NO. _____		Area Name and No. MAIN TRANSMISSION – 9		Aircraft Serial No.		Date		
Inspect Phase Nos.	Inspection Requirements	Status	Faults and/or Remarks	Action Taken	Initial			
2,4 C	27. Engine controls for damage or deformed cables. Supports, clamps, and brackets for cracks and bends. Rods and rod ends for loose and worn bearings. Bellcranks for cracks, deformation, worn bushings, loose or missing hardware, and evidence of interference. Access L200, R200							
ALL	28. Engine start relay box for oil contamination and drain hole obstructions.							

“FOD REMINDER”

Check work area for tools and parts after completion of maintenance and inspection.

PHASE NO. _____		PHASED MAINTENANCE CHECKLIST			
Area Name and No. MAIN ROTOR – 10		Aircraft Serial No.		Date	Total Hrs. This Area
Inspect Phase Nos.	Inspection Requirements	Status	Faults and/or Remarks	Action Taken	Initial
ALL C	1. Blade spars and root finger doublers for delamination.				
ALL C	2. Blade leading edges for cracks, dents, distortion, or erosion. Leading edge tips for loose or missing hardware. Trailing edge for cracks and voids.				
ALL C	3. Perform coin tap test on main rotor blades.				
ALL C	4. Blade root bushings for cracks, distortion, and security.				
2,4 C	5. Rotor drive plate for cracks, distortion, or corrosion. Mounting bolts for security.				

“FOD REMINDER”

Check work area for tools and parts after completion of maintenance and inspection.

TM 1-1520-238-PM

PHASE NO. _____		Area Name and No. MAIN ROTOR – 10		Aircraft Serial No.		Date
Inspect Phase Nos.	Inspection Requirements	Status	Faults and/or Remarks	Action Taken	Initial	
2,4 C	6. Rotor hub for cracks, distortion, corrosion, and security. Hub lower grease seal for leakage.					
2,4 C	7. Feathering bearing housings and retaining nuts for cracks, corrosion, and security. Feathering bearings for radial looseness.					
2,4 C	8. Blade droop stop plates for distortion. Droop stop plungers, return springs, and stop ring for cracks or deformation. Plungers, rollers, and stop ring for wear or play.					

“FOD REMINDER”

Check work area for tools and parts after completion of maintenance and inspection.

TM 1-1520-238-PM

PHASE NO. _____		Area Name and No. MAIN ROTOR – 10		Aircraft Serial No.		Date		
Inspect Phase Nos.	Inspection Requirements	Status	Faults and/or Remarks	Action Taken		Initial		
2,4 C	9. Pitch housings for cracks, scratches, corrosion, and security. Housing ears for pitch link rod end gouging.							
2,4 C	10. Lead-lag links for cracks, nicks, scratches and gouges. Link-to-damper rod ends for bearing damage. Rod ends and bearings for looseness, condition and type bushing liners.							
2,4 C	11. Lead-lag dampers for security and loose, debonded, or deteriorated elastic material. INSPECT FOR AN ACCUMULATION OF DIRT AND DEBRIS IN THE LEAD LAG LINK CAVITY. DISCONNECT DAMPER ROD ENDS FROM LEAD LAG LINKS AND CHECK FOR FREEDOM OF MOVEMENT. IF DIRT AND DEBRIS ARE FOUND OR LINK IS BINDING DISASSEMBLE, CLEAN, AND REASSEMBLE LEAD LAG LINK JOINT AS REQUIRED. DO NOT USE SOLID FILM LUBRICANT FOR REASSEMBLY.							

“FOD REMINDER”

Check work area for tools and parts after completion of maintenance and inspection.

TM 1-1520-238-PM

PHASE NO. _____		Area Name and No. MAIN ROTOR – 10		Aircraft Serial No.		Date	
Inspect Phase Nos.	Inspection Requirements	Status	Faults and/or Remarks	Action Taken		Initial	
ALL C	12. Pitch links for cracks, distortion, and corrosion. Rod ends for bearing damage or looseness. Check lower rod end clamp-up to floating bushings.						
ALL C	13. Swashplate uniball for cracks, grooving, flaked or worn-through plating.						
ALL C	14. Rotating swashplate for cracks, corrosion, grease leakage, and security of lower seal. Pitch link connection bosses for bending, misalignment, and worn or loose bushings.						
ALL C	15. Stationary swashplate for cracks and corrosion. Lateral and torque link connection bosses for bending, misalignment, and worn or loose bushings. Access T205L, T205R, T225						

“FOD REMINDER”

Check work area for tools and parts after completion of maintenance and inspection.

TM 1-1520-238-PM

PHASE NO. _____		Area Name and No. MAIN ROTOR – 10		Aircraft Serial No.		Date
Inspect Phase Nos.	Inspection Requirements	Status	Faults and/or Remarks	Action Taken		Initial
ALL C	16. Rotating scissors for cracks, corrosion, and security. Pivot bearings for wear.					
ALL C	17. Longitudinal and lateral torque links for cracks, dents, scratches, and corrosion. Attachment bolts for security. Bearings for looseness. Access T205L, T205R, T255					
ALL C	18. Longitudinal, lateral, and collective bellcranks for cracks, distortion, and corrosion. Check floating bushing clamp-up to rod ends. Access T205L, T205R, T255					

“FOD REMINDER”

Check work area for tools and parts after completion of maintenance and inspection.

TM 1-1520-238-PM

PHASE NO. _____		Area Name and No. MAIN ROTOR – 10		Aircraft Serial No.		Date	
Inspect Phase Nos.	Inspection Requirements	Status	Faults and/or Remarks	Action Taken		Initial	
ALL C	19. Lower shoe for worn scissors bearing.						
ALL C	20. Main rotor hub nut for corrosion, stripped threads, cracks, or failure. Magnetic particle inspect hub nut.						
ALL C	21. Check rotor hub static droop angle.						
2,4 C	22. Mast tube for cracks, dents, distortion, or corrosion. Swashplate sliding surface for grooved, flaked, or worn-through plating.						

“FOD REMINDER”

Check work area for tools and parts after completion of maintenance and inspection.

TM 1-1520-238-PM

PHASE NO. _____		Area Name and No. MAIN ROTOR – 10		Aircraft Serial No.		Date
Inspect Phase Nos.	Inspection Requirements	Status	Faults and/or Remarks	Action Taken	Initial	
2,4 C	23. Blade de-icing housing for damage or drive plate misalignment.					
2,4 C	24. Check main rotor upper bearing using 12x magnifying glass. Check bearing grease for contamination and burning. Repack bearing.					
2,4 C	25. Check main rotor lower bearing using 12x magnifying glass. Check bearing grease for contamination and burning. Repack bearing.					
ALL C	26. Main rotor gear shaft for cracks, distortion, corrosion, and for chipped, broken, scored or worn spline teeth.					

“FOD REMINDER”

Check work area for tools and parts after completion of maintenance and inspection.

PHASE NO. _____		PHASED MAINTENANCE CHECKLIST			
Area Name and No. AFT EQUIPMENT BAY – 11		Aircraft Serial No.		Date	Total Hrs. This Area
Inspect Phase Nos.	Inspection Requirements	Status	Faults and/or Remarks	Action Taken	Initial
ALL	1. Latches and lanyards for security and proper operation.				
ALL C	2. Structural mating surfaces and fairings for worn, non-adhering, or missing chafe tape/EMI coating. Access R325, L325				
ALL	3. Interior components for mounting security and loose or missing hardware.				
ALL	4. Interior structure for cracks, corrosion, loose, or working rivets, and loose or missing hardware.				

“FOD REMINDER”

Check work area for tools and parts after completion of maintenance and inspection.

TM 1-1520-238-PM

PHASE NO. _____		Area Name and No. AFT EQUIPMENT BAY – 11		Aircraft Serial No.		Date
Inspect Phase Nos.	Inspection Requirements	Status	Faults and/or Remarks	Action Taken	Initial	
2,4	5. Transmission accessory gearcase for oil leakage and component security. Access L325, T250L, T290L, T250R, T290R					
2,4	6. Shaft driven compressor for cracks, oil leakage, and security. Access L325, T250L, T290L, T250R, T290R					
ALL C	7. Shaft driven compressor surge and throttle valves for mounting security. Access L325, T250L, T290L, T250R, T290R					
ALL	8. Shaft driven compressor inlet and outlet hoses for cracks, evidence of air leakage, and security. Access L325, T250L, T290L, T250R, T290R					

“FOD REMINDER”

Check work area for tools and parts after completion of maintenance and inspection.

TM 1-1520-238-PM

PHASE NO. _____		Area Name and No. AFT EQUIPMENT BAY – 11		Aircraft Serial No.		Date
Inspect Phase Nos.	Inspection Requirements	Status	Faults and/or Remarks	Action Taken	Initial	
ALL	9. Shaft driven compressor oil filter for contamination. Access L325, T205L, T290L, T250R, T290R					
ALL	10. Rotor brake actuator for fluid leakage. Brake lining and disk for wear, grooving, or cracks. Pressure switch for fluid leakage. Hydraulic line for leakage and connection security. Access L325, T205L, T290L, T250R, T290R					
ALL	11. Air particle separator for cracks, dents, and security. Remove barrier filter and inspect for damage and cleanliness. Clean APS per TM 1-1520-238-23. Access L325, T250L, T290L, T250R, T290R					
2,4	12. Wiring harnesses for loose connections, chafing, or deterioration. Access L325, T250L, T290L, T250R, T290R					

“FOD REMINDER”

Check work area for tools and parts after completion of maintenance and inspection.

TM 1-1520-238-PM

PHASE NO. _____		Area Name and No. AFT EQUIPMENT BAY – 11		Aircraft Serial No.		Date		
Inspect Phase Nos.	Inspection Requirements	Status	Faults and/or Remarks	Action Taken		Initial		
2,4 C	13. FIRE EXTINGUISHER CONTAINERS FOR DENTS AND MOUNTING SECURITY. CARTRIDGES, FITTINGS, AND VALVES FOR CRACKS, DISTORTION, AND SECURITY. CHECK CONTAINER CHARGE PRESSURE. INSPECT DISCHARGE INDICATING DISK. INSPECT THE SYSTEM CHECK VALVES FOR INTERIOR CORROSION, PITTING, AND EVIDENCE OF EVAPORATION. Access L325, T250L, T290L, T250R, T290R							
ALL C	14. Fire extinguisher outlet tubing and fittings for cracks, dents, distortion, security and corrosion. Access L325, T250L, T290L, T250R, T290R							
ALL C	15. Tail rotor drive shafts and couplings for cracks, dents, distortion, or corrosion. Balancing tapes for security if externally mounted. Access L325, T250L, T290L, T250R, T290R – forward catwalk removed for access.							

“FOD REMINDER”

Check work area for tools and parts after completion of maintenance and inspection.

TM 1-1520-238-PM

PHASE NO. _____		Area Name and No. AFT EQUIPMENT BAY – 11		Aircraft Serial No.		Date
Inspect Phase Nos.	Inspection Requirements	Status	Faults and/or Remarks	Action Taken		Initial
ALL C	16. Tail rotor drive shaft and coupling bolts for proper installation. Access L325, T250L, T290L, T250R, T290R					
ALL C	17. Tail rotor drive shaft forward hanger for cracks, corrosion, mounting security, and for radial looseness and smooth operation. Hanger bearing for smooth rotation. Drive shaft forward hanger bearing support for torque of attaching bolts. Check center nut for torque stripe. Access L325, T250L, T290L, T250R, T290R					
ALL C	18. Drive shaft damper for cracks and proper friction adjustments. Access L325, T250L, T290L, T250R, T290R					
ALL C	19. Drive shaft anti-flail unit for cracks, distortion, and mounting security. Access L325, T250L, T290L, T250R, T290R					

“FOD REMINDER”

Check work area for tools and parts after completion of maintenance and inspection.

TM 1-1520-238-PM

PHASE NO. _____		Area Name and No. AFT EQUIPMENT BAY – 11		Aircraft Serial No.		Date	
Inspect Phase Nos.	Inspection Requirements	Status	Faults and/or Remarks	Action Taken		Initial	
2,4 C	20. Louver actuators for cracks, deformation, and security. Access L230, R230, L325, T250L, T290L, T250R, T290R						
ALL	21. APU enclosure covers and panels for cracks, delamination, seal damage, loose or missing fasteners, and security. Access L325, T250L, T290L, T250R, T290R						
ALL	22. APU drive shaft and couplings for cracks, dents, distortion, corrosion, and evidence of interference. Access L325, T250L, T290L, T250R, T290R						
ALL	23. APU drive shaft coupling bolts for proper torque. Access L325, T250L, T290L, T250R, T290R						

“FOD REMINDER”

Check work area for tools and parts after completion of maintenance and inspection.

TM 1-1520-238-PM

PHASE NO. _____		Area Name and No. AFT EQUIPMENT BAY – 11		Aircraft Serial No.		Date
Inspect Phase Nos.	Inspection Requirements	Status	Faults and/or Remarks	Action Taken		Initial
ALL	24. APU mounts for cracks, dents, distortion and corrosion. Access L325, T250L, T290L, T250R, T290R					
ALL	25. APU for cracks in compressor inlet shroud, turbine plenum, or gearbox housing. Access L325, T250L, T290L, T250R, T290R					
ALL	26. APU starter for cracks, leakage, and security. Access L325, T250L, T290L, T250R, T290R					
ALL	27. APU combustor for cracks or burned-through areas. Access L325, T250L, T290L, T250R, T290R					
2,4	28. APU exhaust system for cracks and loose or missing hardware. Access L325, T250L, T290L, T250R, T290R					

“FOD REMINDER”

Check work area for tools and parts after completion of maintenance and inspection.

TM 1-1520-238-PM

PHASE NO. _____		Area Name and No. AFT EQUIPMENT BAY – 11		Aircraft Serial No.		Date	
Inspect Phase Nos.	Inspection Requirements	Status	Faults and/or Remarks	Action Taken		Initial	
2,4	29. APU exhaust fairing for cracks, corrosion, and loose or missing hardware. Insulated exhaust duct for distortion, cracks, or oxidation. Access L325, T250L, T250R, T290L, T290R						
2,4 C	30. Change APU lube oil and filter. Access L325, T250L, T250R, T290L, T290R						
ALL	31. Change APU fuel filter. Access L325, T250L, T250R, T290L, T290R						
ALL	32. ENCU for security, loose or missing hardware. Wiring for loose connections, chafing, or deterioration. Access L325, T250L, T250R, T290L, T290R						
ALL	33. Change ENCU temperature control valve. Access L325, T250L, T250R, T290L, T290R						

“FOD REMINDER”

Check work area for tools and parts after completion of maintenance and inspection.

TM 1-1520-238-PM

PHASE NO. _____		Area Name and No. AFT EQUIPMENT BAY – 11		Aircraft Serial No.		Date		
Inspect Phase Nos.	Inspection Requirements	Status	Faults and/or Remarks	Action Taken		Initial		
2,4 C	34. ENCU DUCTING FOR CRACKS, CHAFED, LOOSE, OR TORN INSULATION, AND STRIPPED OR MISSING NUT PLATES. REMOVE ENCU FILTER AND INSPECT FOR DAMAGE AND CLEANLINESS. Access L325, T250L, T290L, T250R, T290R							
ALL	35. ENCU outlet duct for chafing against fire extinguishing tube(s)/line(s). Access L325, T250L, T290L, T250R, T290R							
2,4 C	36. ENCU exhaust fairing for cracks, corrosion, and loose or working rivets. Access L325, T250L, T290L, T250R, T290R							
ALL C	37. Flight control linkage for bent, cracked, or corroded push-pull rods. Rod end bearings worn or seized. Brackets cracked or broken. Bellcranks for cracks, corrosion, worn, or seized bearings, and evidence of interference. Access L325, T250L, T290L, T250R, T290R							

“FOD REMINDER”

Check work area for tools and parts after completion of maintenance and inspection.

TM 1-1520-238-PM

PHASE NO. _____		Area Name and No. AFT EQUIPMENT BAY – 11		Aircraft Serial No.		Date	
Inspect Phase Nos.	Inspection Requirements	Status	Faults and/or Remarks	Action Taken		Initial	
ALL C	38. Left and right engine inboard supports for cracks, distortion, corrosion, loose or missing fasteners, and mounting security Access L325, T250L, T290L, T250R,T290R						
ALL C	39. Catwalk and supporting structure for cracks, debonding, distortion, loose or missing fasteners, and security. Walk-way coating for peeling or deterioration. Access L325, T250L, T290L, T250R, T290R						
2,4 C	40. Utility accumulator tubing for leakage and security. Access L325, T250L, T290L, T250R, T290R						
ALL C	41. Utility hydraulic manifold for leakage, corrosion, loose connections, and security. Sight gage for proper fluid level. Check manifold air inlet. Check valve filter for cleanliness. Access R325						

“FOD REMINDER”

Check work area for tools and parts after completion of maintenance and inspection.

TM 1-1520-238-PM

PHASE NO. _____		Area Name and No. AFT EQUIPMENT BAY – 11		Aircraft Serial No.		Date
Inspect Phase Nos.	Inspection Requirements	Status	Faults and/or Remarks	Action Taken	Initial	
ALL	42. PRIMARY and UTILITY hydraulic ground service panels for security. Panel quick-disconnect couplings for fluid leakage Access R325					
ALL	43. Bleed primary and utility hydraulic systems. (actuate flight controls to bleed pressure). Access R325					
ALL	44. VERIFY UTILITY ACCUMULATOR AIR PRESSURE. Access R325					

“FOD REMINDER”

Check work area for tools and parts after completion of maintenance and inspection.

PHASE NO. _____		PHASED MAINTENANCE CHECKLIST			
Area Name and No. MID AND LOWER FUSELAGE – 12		Aircraft Serial No.		Date	Total Hrs. This Area
Inspect Phase Nos.	Inspection Requirements	Status	Faults and/or Remarks	Action Taken	Initial
ALL	1. Fairing and mating fuselage surface for missing, worn, or non-adhering chafe tape. Access T355				
ALL	2. Interior components for mounting security and loose or missing hardware.				
ALL	3. Interior structure for cracks, corrosion, loose or working rivets, and loose or missing hardware.				

“FOD REMINDER”

Check work area for tools and parts after completion of maintenance and inspection.

TM 1-1520-238-PM

PHASE NO. _____		Area Name and No. MID AND LOWER FUSELAGE – 12		Aircraft Serial No.		Date
Inspect Phase Nos.	Inspection Requirements	Status	Faults and/or Remarks	Action Taken		Initial
ALL	4. Remove area weapon, turret fairing, and turret. Return area weapon to AVUM for inspection/repair. Access B90, B120					
ALL	5. Area weapon for evidence of hydraulic fluid leakage. Turret hoses and lines for leakage, corrosion, and security. Wiring harness for loose connections, chafing or deterioration. Access B90, B120					
ALL	6. Gun turret gun cradle support fork shouldered shafts for corrosion, galling, and excessive wear (TM 9-1090-208-23-1-1).					
ALL	7. FUSELAGE TURRET CAVITY FOR CRACKS, CORROSION, DISTORTION, STRINGER BENDING OR MISALINEMENT. AMMO CHUTES FOR CRACKS, DENTS OR DISTORTION, WEAR, AND LUBRICATION. GUN AREA BULKHEADS FOR WEB CRACKS. Access B75R, B90, B120					

“FOD REMINDER”

Check work area for tools and parts after completion of maintenance and inspection.

TM 1-1520-238-PM

PHASE NO. _____		Area Name and No. MID AND LOWER FUSELAGE – 12		Aircraft Serial No.		Date
Inspect Phase Nos.	Inspection Requirements	Status	Faults and/or Remarks	Action Taken	Initial	
2,4	8. Pilot directional pedal control linkage cover for cracks, corrosion, distortion, and loose or missing hardware. Access B90, B120, gun and turret removed.					
ALL C	9. Flight control rods for dents, cracks, corrosion, security, and evidence of interference. Rod ends for looseness. Access B80L, B80R, B75R, B85L, B85R					
ALL C	10. Flight control bellcranks for cracks, corrosion, and security. Brackets for mounting security and evidence of interference. Pivot bearings for looseness. Check floating bushing clamp-up. Access B75R, B85L, B85R					

“FOD REMINDER”

Check work area for tools and parts after completion of maintenance and inspection.

TM 1-1520-238-PM

PHASE NO. _____		Area Name and No. MID AND LOWER FUSELAGE – 12		Aircraft Serial No.		Date
Inspect Phase Nos.	Inspection Requirements	Status	Faults and/or Remarks	Action Taken	Initial	
ALL C	11. PILOT DECOUPLER (SPAD) UNITS FOR CRACKS, CORROSION, SECURITY, EVIDENCE OF INTERFERENCE, AND FOR LOOSENESS OR LOST MOTION. Access B75R, B90, B120					
2,4 C	12. Pilot decoupler shear pins for damage or partial shearing. (BUCS AIRCRAFT ONLY) Access B90, B120					
2,4 C	13. PERFORM ADJUSTMENT AND ELECTRICAL CHECK ON PILOT DECOUPLER (SPAD) UNITS MICROSWITCHES. (BUCS AIRCRAFT ONLY) Access B90, B120					

“FOD REMINDER”

Check work area for tools and parts after completion of maintenance and inspection.

TM 1-1520-238-PM

PHASE NO. _____		Area Name and No. MID AND LOWER FUSELAGE – 12		Aircraft Serial No.		Date		
Inspect Phase Nos.	Inspection Requirements	Status	Faults and/or Remarks	Action Taken		Initial		
ALL C	14. LVDTs for cracks, corrosion, and mounting security. Wiring harness for loose connections, chafing, or deterioration and evidence of interference. Rod ends for looseness. Access B80L, B80R, B85L, B85R							
2,4 C	15. Ammo bay interior bulkheads for cracks, distortion, or corrosion. Stringers for bending or misalignment. Access B200 – ammo magazine removed for access.							
2,4 C	16. Ammo bay interior wing support structure for cracks, corrosion, loose or missing fasteners, and security. Access B200 – ammo magazine removed for access.							
ALL C	17. Ammo bay interior fuel cell stress panels for cracks, delamination, distortion, loose or missing fasteners. Fuel vent tube for chafing. Access B200 – ammo magazine removed for access.							

“FOD REMINDER”

Check work area for tools and parts after completion of maintenance and inspection.

TM 1-1520-238-PM

PHASE NO. _____		Area Name and No. MID AND LOWER FUSELAGE – 12		Aircraft Serial No.		Date
Inspect Phase Nos.	Inspection Requirements	Status	Faults and/or Remarks	Action Taken	Initial	
2,4 C	18. AMMO BAY INTERIOR MAST STRUT SUPPORT STRUCTURE (transmission deck bottom corners) FOR CRACKS, DISTORTION, OR LOOSENESS. Access B200 – ammo magazine removed for access.					
2,4 C	19. AMMO BAY INTERIOR FLIGHT CONTROL SERVO ACTUATOR SUPPORT STRUCTURE (transmission deck bottom forward) FOR CRACKS, DISTORTION, OR LOOSENESS. Access B200 – ammo magazine removed for access.					
2,4	20. Ammo bay interior fuel pumps and valves, pressure switches, manifold, couplings, connectors, and fittings for leakage, cracks, loose connections, and security. Access B200 – ammo magazine removed for access.					

“FOD REMINDER”

Check work area for tools and parts after completion of maintenance and inspection.

TM 1-1520-238-PM

PHASE NO. _____		Area Name and No. MID AND LOWER FUSELAGE – 12		Aircraft Serial No.		Date		
Inspect Phase Nos.	Inspection Requirements	Status	Faults and/or Remarks	Action Taken		Initial		
ALL	21. Ammo bay interior fuel and hydraulic lines, hoses, vent and drain tubes for leakage, chafing, corrosion, and security. Refueling line coupling assemblies for torque stripe and evidence of slippage or leakage. Access B200 – ammo magazine removed for access.							
2,4	22. Ammo bay interior wiring harness for loose connections, chafing, or deterioration. Access B200 – ammo magazine removed for access.							
2,4	23. Ammo magazine support struts for corrosion, bent tube, cracked or broken clevis, and loose or missing rivets. Access B200 – ammo magazine removed for access.							

“FOD REMINDER”

Check work area for tools and parts after completion of maintenance and inspection.

TM 1-1520-238-PM

PHASE NO. _____		Area Name and No. MID AND LOWER FUSELAGE – 12		Aircraft Serial No.		Date
Inspect Phase Nos.	Inspection Requirements	Status	Faults and/or Remarks	Action Taken	Initial	
ALL C	24. Nitrogen inert components for mounting security, loose or missing hardware, failure of tubes or hoses, and distorted or fractured breakaway valves. Filter drain for obstructions. Access R200, T290L, T290R, B200 – ammo magazine and fuel cell access panels removed for access.					
2,4 C	25. MLG cross tube for nicks, scratches, fractures, or corrosion. B105 – area weapon and turret removed for interior access.					
2,4	26. Aft avionics equipment for proper stowage, external damage, or loose connectors. Wiring harness for chafing or deterioration. Access L295, R295					

“FOD REMINDER”

Check work area for tools and parts after completion of maintenance and inspection.

TM 1-1520-238-PM

PHASE NO. _____		Area Name and No. MID AND LOWER FUSELAGE – 12		Aircraft Serial No.	Date
Inspect Phase Nos.	Inspection Requirements	Status	Faults and/or Remarks	Action Taken	Initial
2,4	27. Aft stowage and avionics compartments for cleanliness, cracks, distortion, corrosion, loose or missing rivets or fasteners. Seals for deterioration, proper fit, and evidence of leakage. Access L295, R295				
2,4	28. Fuselage stowage compartments for cracks, distortion, corrosion, and loose or missing rivets or fasteners. Access L330, R330				

“FOD REMINDER”

Check work area for tools and parts after completion of maintenance and inspection.

PHASE NO. _____		PHASED MAINTENANCE CHECKLIST			
Area Name and No. TAILBOOM – 13		Aircraft Serial No.		Date	Total Hrs. This Area
Inspect Phase Nos.	Inspection Requirements	Status	Faults and/or Remarks	Action Taken	Initial
ALL	1. Tail rotor drive shaft fairings and mating surfaces for worn, non-adhering, or missing chafe tape/EMI coating. Access R410, R475				
ALL	2. Interior components for mounting security and loose or missing hardware.				
ALL	3. Tailboom deck structure for cracks, distortion, corrosion, loose or working rivets, and loose or missing hardware.				
ALL C	4. Tail rotor drive shaft and couplings for cracks, dents, distortion, corrosion, and evidence of interference. Access R410, R475				

“FOD REMINDER”

Check work area for tools and parts after completion of maintenance and inspection.

TM 1-1520-238-PM

PHASE NO. _____		Area Name and No. TAILBOOM – 13		Aircraft Serial No.		Date
Inspect Phase Nos.	Inspection Requirements	Status	Faults and/or Remarks	Action Taken	Initial	
ALL C	5. Tail rotor drive shaft and coupling bolts for proper installation. Access R410, R475					
ALL C	6. Tail rotor drive shaft aft hanger for cracks or corrosion. Hanger bracket for cracks and mounting security. Hanger bearing for smooth rotation, nutation and center nut torque stripe. Access R410, R475					
ALL C	7. Anti-flail units for cracks, distortion, and mounting security. Access R410, R475					
ALL C	8. Drive shaft dampers for cracks and wear. Access R410, R475					

“FOD REMINDER”

Check work area for tools and parts after completion of maintenance and inspection.

TM 1-1520-238-PM

PHASE NO. _____		Area Name and No. TAILBOOM – 13		Aircraft Serial No.		Date	
Inspect Phase Nos.	Inspection Requirements	Status	Faults and/or Remarks	Action Taken		Initial	
ALL C	9. Drive shaft damper brackets for cracks, dents, corrosion, and mounting security. Access R410, R475						
ALL C	10. Drive shaft dampers for proper friction adjustment. Access R410, R475						
ALL C	11. Tail rotor flight control rods for dents, cracks, corrosion, security, and evidence of interference. Check rod ends for looseness. Check wear sleeves for debond and excessive wear. Access R410, R475						
ALL C	12. Tail rotor flight control bellcranks for cracks, corrosion, security, and evidence of interference. Pivot bearings for looseness. Access R410, R475						

“FOD REMINDER”

Check work area for tools and parts after completion of maintenance and inspection.

TM 1-1520-238-PM

PHASE NO. _____		Area Name and No. TAILBOOM – 13		Aircraft Serial No.		Date
Inspect Phase Nos.	Inspection Requirements	Status	Faults and/or Remarks	Action Taken	Initial	
2,4	13. Tailboom interior hydraulic components and lines for leakage, dents, corrosion, chafing and security. Access L330, R330					
2,4	14. Tailboom interior wiring harness for chafing, deterioration, and security. Access L330, R330					
ALL C	15. Tailboom armor components for cracked or broken plates or channels, and loose or missing hardware. Access T355, R410, R475					

“FOD REMINDER”

Check work area for tools and parts after completion of maintenance and inspection.

TM 1-1520-238-PM

PHASE NO. _____		Area Name and No. TAILBOOM – 13		Aircraft Serial No.		Date		
Inspect Phase Nos.	Inspection Requirements	Status	Faults and/or Remarks	Action Taken	Initial			
ALL C	16. Formation light for corrosion, loose or missing fasteners, and security. Lenses for cracks, looseness, or discoloration. Wiring harness for loose connections or chafing. L325 open							
2,4 C	17. TAILBOOM SPLICE (FS 436.5/476.6) FOR SHEARED OR WORKING RIVETS, CORROSION, AND CRACKED OR DEFORMED SKIN.							

“FOD REMINDER”

Check work area for tools and parts after completion of maintenance and inspection.

PHASE NO. _____		PHASED MAINTENANCE CHECKLIST			
Area Name and No. EMPENNAGE, TAIL ROTOR, AND TLG – 14		Aircraft Serial No.		Date	Total Hrs. This Area
Inspect Phase Nos.	Inspection Requirements	Status	Faults and/or Remarks	Action Taken	Initial
ALL	1. Structural flanges and fairings on vertical stabilizer for worn, non-adhering, or missing chafe tape/EMI coating. Access R510, L510, L530, L540				
ALL	2. Interior components for mounting security and loose or missing hardware. Access L545, R545				
ALL	3. Interior structure for cracks, corrosion, loose or working rivets, and loose or missing hardware.				
2,4 C	4. Stabilizer navigation and formation lights for corrosion, loose or missing fasteners, and security. Lenses for cracks, looseness, or discoloration. Wiring harness for loose connections or chafing. Remove R578 for interior access.				

“FOD REMINDER”

Check work area for tools and parts after completion of maintenance and inspection.

TM 1-1520-238-PM

PHASE NO. _____		Area Name and No. EMPENNAGE, TAIL ROTOR, AND TLG – 14		Aircraft Serial No.		Date		
Inspect Phase Nos.	Inspection Requirements	Status	Faults and/or Remarks	Action Taken		Initial		
2,4	5. Stabilizer radar warning antennas, GPS antenna, and FM-AM whip antenna for damage, mounting security, and condition of wiring. Remove T545 for interior access.							
2,4 C	6. Stabilizer spar box for cracks, corrosion, distortion, and loose or working rivets. Access L510, R510, L530, L540, L550							
2,4 C	7. Hydraulic lines and couplings for leaks, cracks, chafing, and clamping security. Access L510, R510, L530, L540, L550							
2,4 C	8. Stabilizer trailing edge fairing for debonding and corrosion.							

“FOD REMINDER”

Check work area for tools and parts after completion of maintenance and inspection.

TM 1-1520-238-PM

PHASE NO. _____		Area Name and No. EMPENNAGE, TAIL ROTOR, AND TLG – 14		Aircraft Serial No.		Date
Inspect Phase Nos.	Inspection Requirements	Status	Faults and/or Remarks	Action Taken	Initial	
ALL C	9. Stabilator structure and skins for cracks, dents, distortion, and loose or missing rivets or fasteners.					
ALL C	10. Stabilator tip fairings for cracks and loose or missing screws.					
ALL C	11. Stabilator actuator for cracked, deformed, or jammed jackscrew, and loose rod end bearings. Wiring for chafing, deterioration, security, and proper connection. Stabilator fittings for cracks, loose or missing hardware, and worn or seized bearings. Access L545, R545					
ALL C	12. Stabilator position transducer for mounting security. wiring for connection security and chafing.					

“FOD REMINDER”

Check work area for tools and parts after completion of maintenance and inspection.

TM 1-1520-238-PM

PHASE NO. _____		Area Name and No. EMPENNAGE, TAIL ROTOR, AND TLG – 14		Aircraft Serial No.		Date		
Inspect Phase Nos.	Inspection Requirements	Status	Faults and/or Remarks	Action Taken		Initial		
ALL C	13. Stabilator pivot bolts, pivot bearings, and pivot bosses for cracks, distortion, corrosion, and cleanliness. Pivot bushings for lateral looseness. Access LS1, RS1, L545, R545 CAUTION: Do not use tail rotor control push rods as hand-holds.							
ALL C	14. Intermediate gearbox housing, input and output retainers for cracks, distortion, and security. Check for grease leakage or evidence of overheating (discoloration). Gearbox mount fittings for cracks or distortion. Grease for proper level. Access L510, R510							
2,4 C	15. Intermediate gearbox mounting bolts for proper torque. Access L510, R510							

“FOD REMINDER”

Check work area for tools and parts after completion of maintenance and inspection.

TM 1-1520-238-PM

PHASE NO. _____		Area Name and No. EMPENNAGE, TAIL ROTOR, AND TLG – 14		Aircraft Serial No.		Date
Inspect Phase Nos.	Inspection Requirements	Status	Faults and/or Remarks	Action Taken	Initial	
2,4	16. Intermediate gearbox thermistors for insulation damage, grease leakage, and security. Wire harness splices for security. Access L510, R510					
ALL C	17. Tail rotor drive shaft and couplings for cracks, dents, distortion, or corrosion. Balancing tapes for security if externally mounted. Access L510, R510, L530, L540					
ALL C	18. Tail rotor drive shaft and coupling bolts for proper installation. Access L510, R510, L530, L540					
ALL C	19. Tail rotor gearbox brace for loose, worn or frozen bearing, cracked or broken fittings, cracked strut, and loose or missing hardware. Access L540					

“FOD REMINDER”

Check work area for tools and parts after completion of maintenance and inspection.

TM 1-1520-238-PM

PHASE NO. _____		Area Name and No. EMPENNAGE, TAIL ROTOR, AND TLG – 14		Aircraft Serial No.		Date		
Inspect Phase Nos.	Inspection Requirements	Status	Faults and/or Remarks	Action Taken		Initial		
ALL C	20. Tail rotor gearbox housing and input and output retainers for cracks, distortion, security, and grease leakage or evidence of overheating (discoloration). Gearbox mount fittings for cracks or distortion. Grease for proper level. Access L530, L540							
ALL	21. Tail rotor gearbox mounting studs for proper torque. Access L530, L540							
2,4	22. Tail rotor gearbox thermistors for insulation damage, grease leakage, and security. Wire harness splices for security. Access L530, L540							

“FOD REMINDER”

Check work area for tools and parts after completion of maintenance and inspection.

TM 1-1520-238-PM

PHASE NO. _____		Area Name and No. EMPENNAGE, TAIL ROTOR, AND TLG – 14		Aircraft Serial No.		Date
Inspect Phase Nos.	Inspection Requirements	Status	Faults and/or Remarks	Action Taken	Initial	
ALL	23. Test tail rotor and intermediate gearbox alarm control unit. Access L530, L540					
ALL C	24. Tail rotor flight control rods for dents, cracks, corrosion, security, and evidence of interference. Check rod ends for looseness and worn or seized bearings. Access L510, L530, L540, R510					
ALL C	25. Tail rotor pitch change links for dents, cracks, corrosion, security, evidence of interference, worn or seized bearings, and tolerance wear limits.					

“FOD REMINDER”

Check work area for tools and parts after completion of maintenance and inspection.

TM 1-1520-238-PM

PHASE NO. _____		Area Name and No. EMPENNAGE, TAIL ROTOR, AND TLG – 14		Aircraft Serial No.		Date		
Inspect Phase Nos.	Inspection Requirements	Status	Faults and/or Remarks	Action Taken		Initial		
2,4 C	26. Tail rotor flight control bellcranks for cracks, corrosion, security, and evidence of interference. Floating bushing clamp-up and pivot bearings for looseness. Access L510, L530, L540, R510							
ALL C	27. Tail rotor flight control servocylinder for leakage, cracks, and corrosion. Rod end and base clevis for bearing damage and attachment security. Rod end for radial looseness. Inspect servocylinder control linkage fasteners for damage and security. Access L530, L540							
2,4	28. Inspect and clean tail rotor flight control servocylinder pressure filter. Access L530, L540							

“FOD REMINDER”

Check work area for tools and parts after completion of maintenance and inspection.

TM 1-1520-238-PM

PHASE NO. _____		Area Name and No. EMPENNAGE, TAIL ROTOR, AND TLG – 14		Aircraft Serial No.		Date
Inspect Phase Nos.	Inspection Requirements	Status	Faults and/or Remarks	Action Taken	Initial	
2,4 C	29. Tail rotor washplates for cracks or corrosion. Looseness between stationary and rotating washplates. Access L530, L540					
2,4 C	30. Tail rotor rotating scissors for cracks, corrosion, and security. Pivot bearings for wear.					
ALL C	31. Tail rotor head for cracks, distortion, corrosion, and security. Check mounting nuts for proper torque.					

“FOD REMINDER”

Check work area for tools and parts after completion of maintenance and inspection.

TM 1-1520-238-PM

PHASE NO. _____		Area Name and No. EMPENNAGE, TAIL ROTOR, AND TLG – 14		Aircraft Serial No.		Date
Inspect Phase Nos.	Inspection Requirements	Status	Faults and/or Remarks	Action Taken	Initial	
ALL C	32. Tail rotor fork yoke teetering bearing for cracks, separation, or deterioration. Teetering bearing center studs for looseness.					
ALL C	33. Tail rotor teetering stops for cracks or distortion.					
ALL C	34. Tail rotor root blade bolt heads and nuts for cracks or looseness.					

“FOD REMINDER”

Check work area for tools and parts after completion of maintenance and inspection.

TM 1-1520-238-PM

PHASE NO. _____		Area Name and No. EMPENNAGE, TAIL ROTOR, AND TLG – 14		Aircraft Serial No.		Date	
Inspect Phase Nos.	Inspection Requirements	Status	Faults and/or Remarks	Action Taken		Initial	
ALL C	35. Tail rotor blade spars and root finger doublers for delamination.						
ALL C	36. Tail rotor blade leading edges for cracks, dents, distortion, or erosion. Leading edge tips for loose or missing hardware.						
ALL C	37. Tail rotor blade bushings (inside root fittings) for looseness. Dust boots for damage, misalignment, and security.						
2,4 C	38. TLG arms for cracks, bending, distortion, and security. Pivot pin and bushing for looseness. Access L545, R545						

“FOD REMINDER”

Check work area for tools and parts after completion of maintenance and inspection.

TM 1-1520-238-PM

PHASE NO. _____		Area Name and No. EMPENNAGE, TAIL ROTOR, AND TLG – 14		Aircraft Serial No.		Date
Inspect Phase Nos.	Inspection Requirements	Status	Faults and/or Remarks	Action Taken	Initial	
2,4 C	39. REPACK TLG WHEEL BEARINGS AND CHECK FOR SMOOTH OPERATION.					
ALL C	40. TLG shock strut for leakage, cracks, distortion, or corrosion. Rod ends for bearing damage.					
2,4 C	41. Tail boom end frame (F.S. 530 & 547.15) for cracks, corrosion, worn or failed bearing or bushing, and loose or working rivets. Access L545, R545, B545					

“FOD REMINDER”

Check work area for tools and parts after completion of maintenance and inspection.

PHASE NO. _____		PHASED MAINTENANCE CHECKLIST			
Area Name and No. POWER ON CHECKS		Aircraft Serial No.		Date	Total Hrs. This Area
Inspect Phase Nos.	Inspection Requirements	Status	Faults and/or Remarks	Action Taken	Initial
ALL C	1. Ensure that all entries on forms, records and work sheets have been completed or updated and new forms initiated as required and/or have been carried forward on DA Form 2408-13 or DA Form 2408-14 in accordance with DA PAM 738-751.				
ALL C	2. Perform 10 Hour/14 Day Inspection IAW TM 1-1520-238-PMS				
ALL C	3. Start APU. TM 1-1520-238-T				

“FOD REMINDER”

Check work area for tools and parts after completion of maintenance and inspection.

TM 1-1520-238-PM

PHASE NO. _____		Area Name and No. POWER ON CHECKS		Aircraft Serial No.		Date
Inspect Phase Nos.	Inspection Requirements	Status	Faults and/or Remarks	Action Taken	Initial	
ALL C	4. Perform FD/LS end to end check.					
ALL C	5. Perform battery charger operational check. TM 11-1520-238-23					
ALL C	6. Operate fuel boost pump for fuel pressure light.					
ALL C	7. Perform fuel system leak-check.					

“FOD REMINDER”

Check work area for tools and parts after completion of maintenance and inspection.

TM 1-1520-238-PM

PHASE NO. _____		Area Name and No. POWER ON CHECKS		Aircraft Serial No.	Date
Inspect Phase Nos.	Inspection Requirements	Status	Faults and/or Remarks	Action Taken	Initial
ALL C	8. Stabilator actuated through full travel range for smooth operation with no lost motion or binding.				
ALL C	9. Forward and aft avionics bay cooling fans for smooth operation.				
ALL C	10. Perform windshield anti-ice system operational check.				
ALL C	11. Operate rotor brake for BRAKE, LOCK, and OFF operational modes.				
ALL C	12. Perform Post-Inspection Maintenance Operational Checks (MOC), as required, IAW requirements of TM 1-1500-328-23.				
ALL C	13. Perform Post-Inspection MTF IAW TM 1-1520-238-MTF and TM 1-1500-328-23.				

“FOD REMINDER”

Check work area for tools and parts after completion of maintenance and inspection.

TM 1-1520-238-PM

By Order of the Secretary of the Army:

Official:



JOEL B. HUDSON

Administrative Assistant to the
Secretary of the Army

0203203

ERIC K. SHINSEKI
General, United States Army
Chief of Staff

DISTRIBUTION:

To be distributed in accordance with Initial Distribution Number (IDN) 313450, requirements for TM 1-1520-238-PM.

THESE ARE THE INSTRUCTIONS FOR SENDING AN ELECTRONIC 2028

The following format must be used if submitting an electronic 2028. The subject line must be exactly the same and all fields must be included; however only the following fields are mandatory: 1, 3, 4, 5, 6, 7, 8, 9, 10, 13, 15, 16, 17, and 27.

From: "Whomever" <whomever@avma27.army.mil>

To: 2028@redstone.army.mil

Subject: DA Form 2028

1. **From:** Joe Smith
2. Unit: Home
3. **Address:** 4300 Park
4. **City:** Hometown
5. **St:** MO
6. **Zip:** 77777
7. **Date Sent:** 19-Oct-93
8. **Pub no:** 55-2840-229-23
9. **Pub Title:** TM
10. **Publication Date:** 04-Jul-85
11. Change Number: 7
12. Submitter Rank: MSG
13. **Submitter Fname:** Joe
14. Submitter Mname: T
15. **Submitter Lname:** Smith
16. **Submitter Phone:** (123) 123-1234
17. **Problem:** 1
18. Page: 2
19. Paragraph: 3
20. Line: 4
21. NSN: 5
22. Reference: 6
23. Figure: 7
24. Table: 8
25. Item: 9
26. Total: 123
27. **Text:**

This is the text for the problem below line 27.

RECOMMENDED CHANGES TO EQUIPMENT TECHNICAL PUBLICATIONS



SOMETHING WRONG WITH THIS PUBLICATION?

THEN . . . JOT DOWN THE DOPE ABOUT IT ON THIS FORM. CAREFULLY TEAR IT OUT, FOLD IT AND DROP IT IN THE MAIL.

FROM: (PRINT YOUR UNIT'S COMPLETE ADDRESS)

SSG John Doe
E. Troop 5th Cav. 1st Training Building
Fort Knox, Kentucky 12345-6789

DATE SENT

21 June 1994

PUBLICATION NUMBER

TM 1-1520-238-PM

PUBLICATION DATE

30 June 1994

PUBLICATION TITLE

Phased Maintenance Inspection Checklist for AH-64A Helicopter

BE EXACT . . . PIN-POINT WHERE IT IS

PAGE NO.	PARA-GRAPH	FIGURE NO.	TABLE NO.
2-4			

IN THIS SPACE TELL WHAT IS WRONG AND WHAT SHOULD BE DONE ABOUT IT:

Item 7. calls out inspection areas 2 and 4. ALL should be listed in this column.

SAMPLE

PRINTED NAME, GRADE OR TITLE, AND TELEPHONE NUMBER

SP4 John Doe, Autovon 555-1212

SIGN HERE

John Doe

TEAR ALONG PERFORATED LINE

RECOMMENDED CHANGES TO EQUIPMENT TECHNICAL PUBLICATIONS



SOMETHING WRONG WITH THIS PUBLICATION?

THEN . . . JOT DOWN THE DOPE ABOUT IT ON THIS FORM. CAREFULLY TEAR IT OUT, FOLD IT AND DROP IT IN THE MAIL.

FROM: (PRINT YOUR UNIT'S COMPLETE ADDRESS)

DATE SENT

PUBLICATION NUMBER

TM 1-1520-238-PM

PUBLICATION DATE

30 June 1994

PUBLICATION TITLE

Phased Maintenance Inspection Checklist for AH-64A Helicopter

BE EXACT . . . PIN-POINT WHERE IT IS

PAGE NO.	PARA-GRAPH	FIGURE NO.	TABLE NO.
----------	------------	------------	-----------

IN THIS SPACE TELL WHAT IS WRONG AND WHAT SHOULD BE DONE ABOUT IT:

TEAR ALONG PERFORATED LINE

PRINTED NAME, GRADE OR TITLE, AND TELEPHONE NUMBER

SIGN HERE

FILL IN YOUR
UNIT'S ADDRESS



FOLD BACK

DEPARTMENT OF THE ARMY

OFFICIAL BUSINESS
PENALTY FOR PRIVATE USE, \$300

POSTAGE AND FEES PAID FOR
DEPARTMENT OF THE ARMY
DOD 314



TEAR ALONG PERFORATED LINE

Commander
U.S. Army Aviation And Missile Command
ATTN: AMSAM-MMC-MA-NP
Redstone Arsenal, AL 35898-5230

RECOMMENDED CHANGES TO EQUIPMENT TECHNICAL PUBLICATIONS



SOMETHING WRONG WITH THIS PUBLICATION?

THEN . . . JOT DOWN THE DOPE ABOUT IT ON THIS FORM. CAREFULLY TEAR IT OUT, FOLD IT AND DROP IT IN THE MAIL.

FROM: (PRINT YOUR UNIT'S COMPLETE ADDRESS)

DATE SENT

PUBLICATION NUMBER

TM 1-1520-238-PM

PUBLICATION DATE

30 June 1994

PUBLICATION TITLE

Phased Maintenance Inspection Checklist for AH-64A Helicopter

BE EXACT . . . PIN-POINT WHERE IT IS

PAGE NO.	PARA-GRAPH	FIGURE NO.	TABLE NO.

IN THIS SPACE TELL WHAT IS WRONG AND WHAT SHOULD BE DONE ABOUT IT:

TEAR ALONG PERFORATED LINE

PRINTED NAME, GRADE OR TITLE, AND TELEPHONE NUMBER

SIGN HERE

FILL IN YOUR
UNIT'S ADDRESS



FOLD BACK

DEPARTMENT OF THE ARMY

OFFICIAL BUSINESS
PENALTY FOR PRIVATE USE, \$300

POSTAGE AND FEES PAID FOR
DEPARTMENT OF THE ARMY
DOD 314



TEAR ALONG PERFORATED LINE

Commander
U.S. Army Aviation And Missile Command
ATTN: AMSAM-MMC-MA-NP
Redstone Arsenal, AL 35898-5230

RECOMMENDED CHANGES TO EQUIPMENT TECHNICAL PUBLICATIONS



SOMETHING WRONG WITH THIS PUBLICATION?

THEN . . . JOT DOWN THE DOPE ABOUT IT ON THIS FORM. CAREFULLY TEAR IT OUT, FOLD IT AND DROP IT IN THE MAIL.

FROM: (PRINT YOUR UNIT'S COMPLETE ADDRESS)

DATE SENT

PUBLICATION NUMBER TM 1-1520-238-PM	PUBLICATION DATE 30 June 1994	PUBLICATION TITLE Phased Maintenance Inspection Checklist for AH-64A Helicopter
---	---	---

BE EXACT . . . PIN-POINT WHERE IT IS				IN THIS SPACE TELL WHAT IS WRONG AND WHAT SHOULD BE DONE ABOUT IT:
PAGE NO.	PARA-GRAPH	FIGURE NO.	TABLE NO.	

PRINTED NAME, GRADE OR TITLE, AND TELEPHONE NUMBER	SIGN HERE
--	-----------

TEAR ALONG PERFORATED LINE

FILL IN YOUR
UNIT'S ADDRESS



FOLD BACK

DEPARTMENT OF THE ARMY

OFFICIAL BUSINESS
PENALTY FOR PRIVATE USE, \$300

POSTAGE AND FEES PAID FOR
DEPARTMENT OF THE ARMY
DOD 314



TEAR ALONG PERFORATED LINE

Commander
U.S. Army Aviation And Missile Command
ATTN: AMSAM-MMC-MA-NP
Redstone Arsenal, AL 35898-5230

The Metric System and Equivalents

Linear Measure

1 centimeter = 10 millimeters = .39 inch
 1 decimeter = 10 centimeters = 3.94 inches
 1 meter = 10 decimeters = 39.37 inches
 1 dekameter = 10 meters = 32.8 feet
 1 hectometer = 10 dekameters = 328.08 feet
 1 kilometer = 10 hectometers = 3,280.8 feet

Weights

1 centigram = 10 milligrams = .15 grain
 1 decigram = 10 centigrams = 1.54 grains
 1 gram = 10 decigrams = .035 ounce
 1 dekagram = 10 grams = .35 ounce
 1 hectogram = 10 dekagrams = 3.52 ounces
 1 kilogram = 10 hectograms = 2.2 pounds
 1 quintal = 100 kilograms = 220.46 pounds
 1 metric ton = 10 quintals = 1.1 short tons

Liquid Measure

1 centiliter = 10 milliliters = .34 fl. ounces
 1 deciliter = 10 centiliters = 3.38 fl. ounces
 1 liter = 10 deciliters = 33.81 fl. ounces
 1 dekaliter = 10 liters = 2.64 gallons
 1 hectoliter = 10 dekaliters = 26.42 gallons
 1 kiloliter = 10 hectoliters = 264.18 gallons

Square Measure

1 sq. centimeter = 100 sq. millimeters = .155 sq. inch
 1 sq. decimeter = 100 sq. centimeters = 15.5 sq. inches
 1 sq. meter (centare) = 100 sq. decimeters = 10.76 sq. feet
 1 sq. dekameter (are) = 100 sq. meters = 1,076.4 sq. feet
 1 sq. hectometer (hectare) = 100 sq. dekameters = 2.47 acres
 1 sq. kilometer = 100 sq. hectometers = .386 sq. mile

Cubic Measure

1 cu. centimeter = 1000 cu. millimeters = .06 cu. inch
 1 cu. decimeter = 1000 cu. centimeters = 61.02 cu. inches
 1 cu. meter = 1000 cu. decimeters = 35.31 cu. feet

Approximate Conversion Factors

<i>To change</i>	<i>To</i>	<i>Multiply by</i>	<i>To change</i>	<i>To</i>	<i>Multiply by</i>
inches	centimeters	2.540	ounce–inches	newton–meters	.007062
feet	meters	.305	centimeters	inches	.394
yards	meters	.914	meters	feet	3.280
miles	kilometers	1.609	meters	yards	1.094
square inches	square centimeters	6.452	kilometers	miles	.621
square feet	square meters	.093	square centimeters	square inches	.155
square yards	square meters	.836	square meters	square feet	10.764
square miles	square kilometers	2.590	square meters	square yards	1.196
acres	square hectometers	.405	square kilometers	square miles	.386
cubic feet	cubic meters	.028	square hectometers	acres	2.471
cubic yards	cubic meters	.765	cubic meters	cubic feet	35.315
fluid ounces	milliliters	29.573	cubic meters	cubic yards	1.308
pints	liters	.473	milliliters	fluid ounces	.034
quarts	liters	.946	liters	pints	2.113
gallons	liters	3.785	liters	quarts	1.057
ounces	grams	28.349	liters	gallons	.264
pounds	kilograms	.454	grams	ounces	.035
short tons	metric tons	.907	kilograms	pounds	2.205
pound–feet	newton–meters	1.356	metric tons	short tons	1.102
pound–inches	newton–meters	.11296			

Temperature (Exact)

° F Fahrenheit temperature $\frac{5}{9}$ (after subtracting 32) Celsius temperature ° C